



"Gulf Armor"

WOOD GLAZED OR OPAQUE DOUBLE DOOR w/ TRANSOM INSWING/OUTSWING "IMPACT"

GENERAL NOTES:

1. This product has been evaluated and is in compliance with the 6th Edition (2017) Florida Building Code (FBC) structural requirements including the "High Velocity Hurricane Zone" (HVHZ).
2. Product anchors shall be as listed and spaced as shown on details. Anchor embedment to base material shall be beyond wall dressing or stucco.
3. When used in the "HVHZ", this product complies with Section 1626 of the Florida Building Code and does not require an impact resistant covering.
4. For 2x stud framing construction, anchoring of these units shall be the same as that shown for 2x buck masonry construction.
5. Site conditions that deviate from the details of this drawing require further engineering analysis by a licensed engineer or registered architect.
6. Outswing configurations meet water infiltration requirements for "HVHZ".
7. Inswing configurations do not meet the water infiltration requirements for the "HVHZ" and shall be installed only in non-habitable areas or at habitable locations protected by an overhang or canopy such that the angle between the edge of canopy or overhang to sill is less than 45 degrees.

TABLE OF CONTENTS

SHEET #	DESCRIPTION
1	Typical Elevations, Design Pressures & General Notes
2	Door Panel Details
3	Door Panel Details
4	Transom Panel Details
5	Glazing & Panel Infil Details
6	Elevations
7	Horizontal & Vertical Cross Sections (2X Buck)
8	Horizontal & Vertical Cross Sections (1X Buck)
9	Vertical Cross Sections (Thresholds)
10	Buck Anchoring
11	Frame Anchoring
12	Hardware Details
13	Bill of Materials & Components

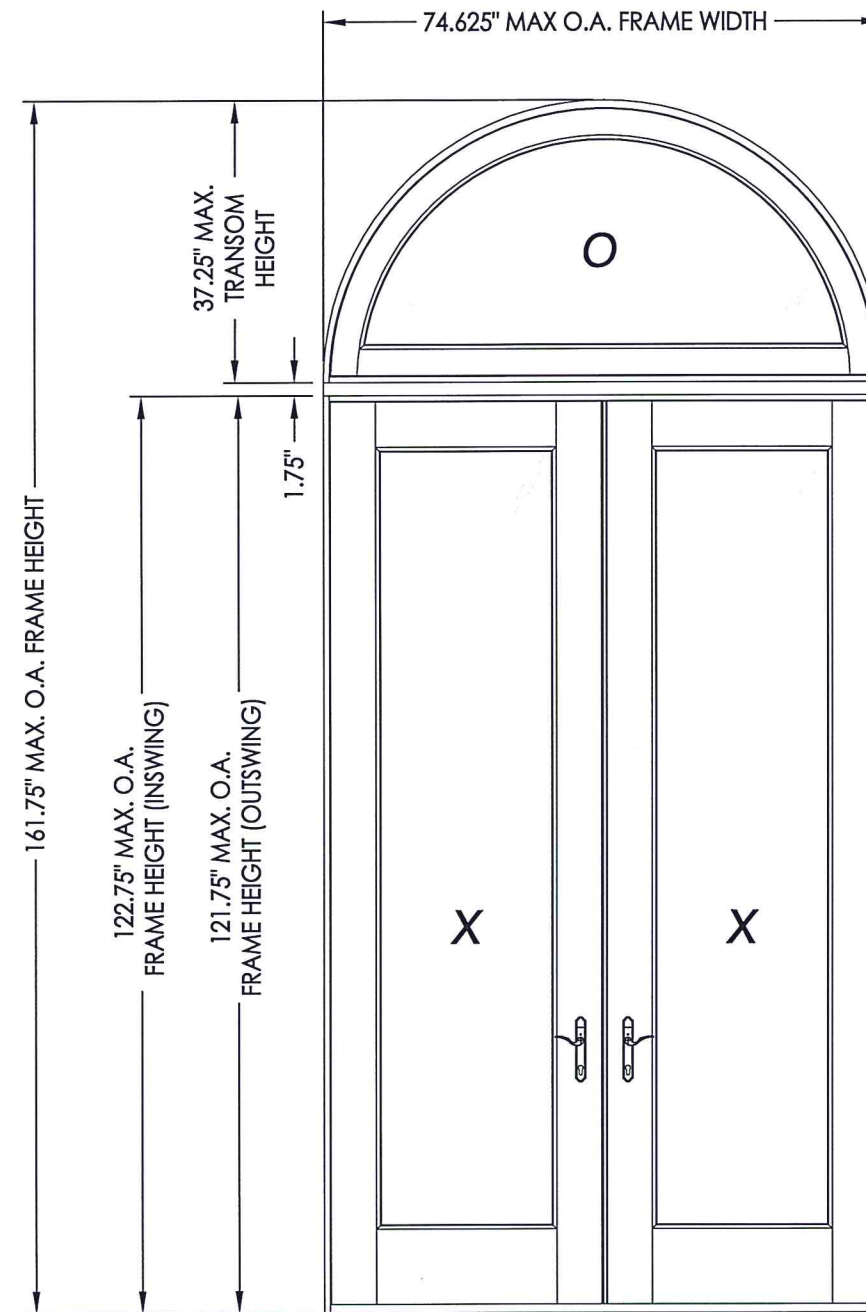

CONFIGURATION	DESIGN PRESSURE (PSF) INSWING		DESIGN PRESSURE (PSF) OUTSWING (WATER INFILTRATION REQUIRED)		DESIGN PRESSURE (PSF) OUTSWING (WATER INFILTRATION NOT REQUIRED)	
	POSITIVE	NEGATIVE	POSITIVE	NEGATIVE	POSITIVE	NEGATIVE
$\frac{O}{XX}$	+60.0	-60.0	+60.0	-65.0	+65.0	-65.0

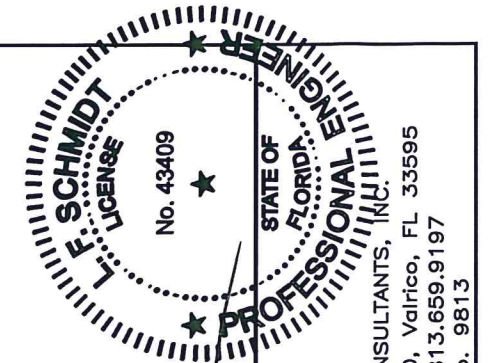

October 12, 2017
 Documents Prepared By:
 Lyndon F. Schmidt
 P.E. No. 43409
 R.W. BUILDING CONSULTANTS, INC.
 P.O. Box 230, Valrico, FL 33595
 Phone No.: 813.659.9197
 FBPE C.A. No. 9813

PRODUCT:
 SOUTHEASTERN SASH & DOOR
 WOOD DOOR
 PART OR ASSEMBLY:
 TYPICAL ELEVATION, DESIGN
 PRESSURES & GENERAL NOTES

NO.	DATE	REVISIONS
1	10/12/17	UPDATE TO 6TH ED. (2017) FBC

DATE: 5/10/17
 SCALE: N.T.S.
 DWG. BY: JK
 CHK. BY: LFS
 DRAWING NO.:
 FL-22347.10
 SHEET 1 OF 13

R:\Clients\Southeastern Sash & Door\A - Florida Product Approvals\FL-22347\C - Drawings\FL 22347 (2017)\FL-22347.9-11.dwg, 10.2

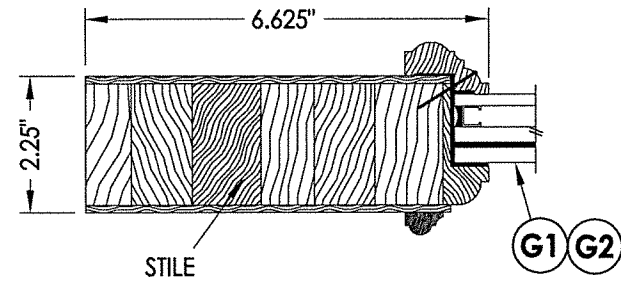

1
2 HORIZONTAL CROSS SECTION

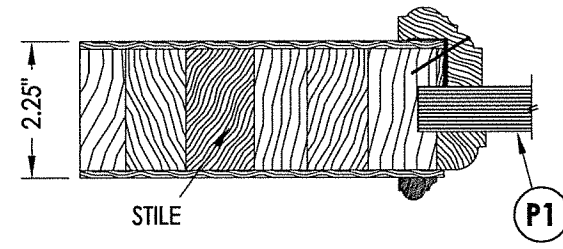

2
2 HORIZONTAL CROSS SECTION

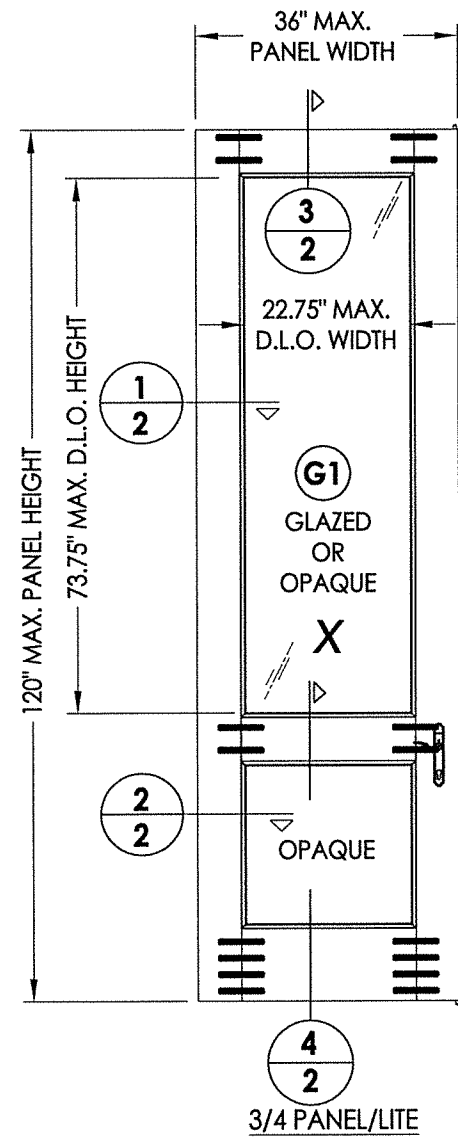

4
2 3/4 PANEL/LITE

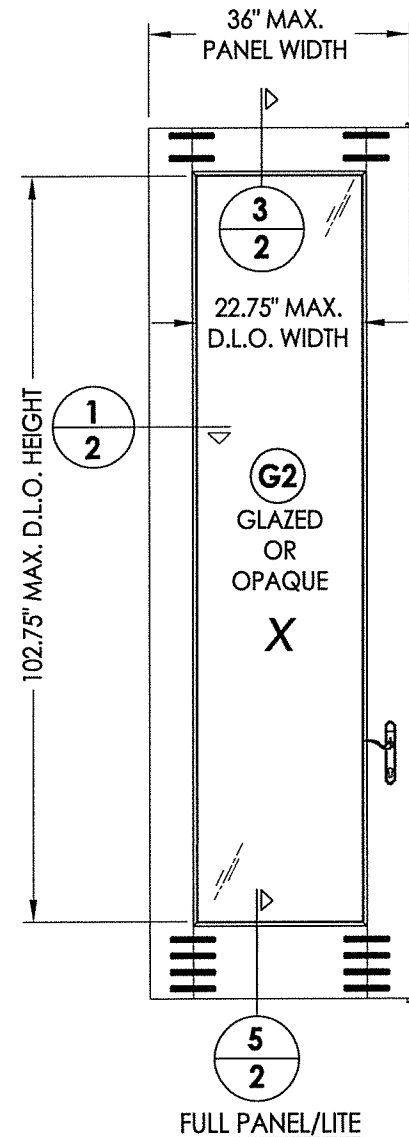

5
2 FULL PANEL/LITE

40 WOOD DOOR PANEL (3'-0")
Glazed or Opaque

WOOD DOOR COMPONENTS:

ENGINEERED STAVE CORE: SIPO (UTILE) (G = 0.53)

VENEER/EDGES: CYPRESS (G = 0.42)

NOTE: VENEER/EDGE MAY INCLUDE OAK, CHERRY, WALNUT OR OTHER OPTIONAL HARDWOOD SPECIES w/ G >= 0.42.

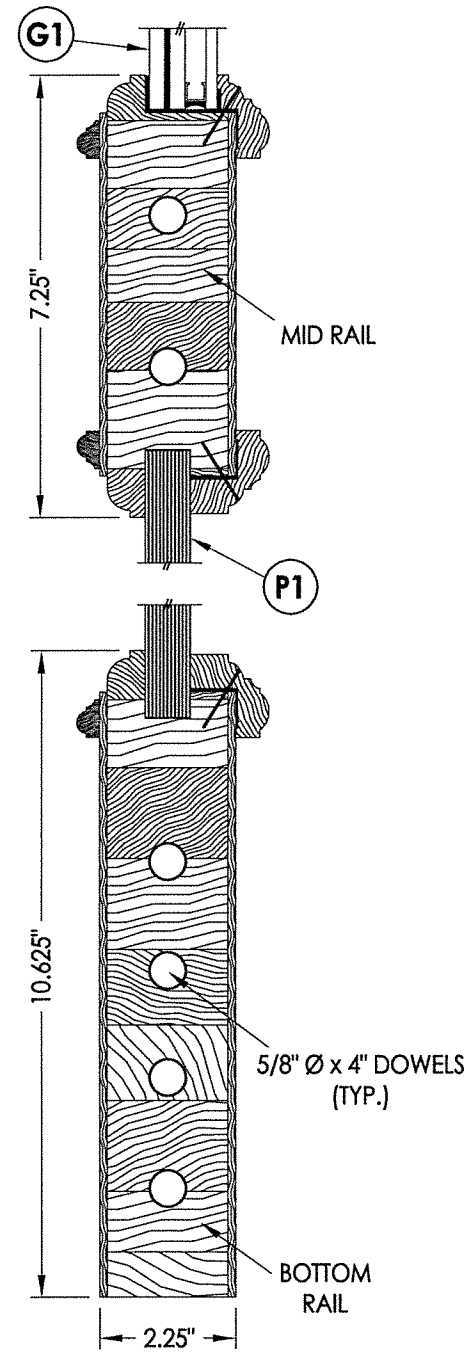

4
2 VERTICAL CROSS SECTION

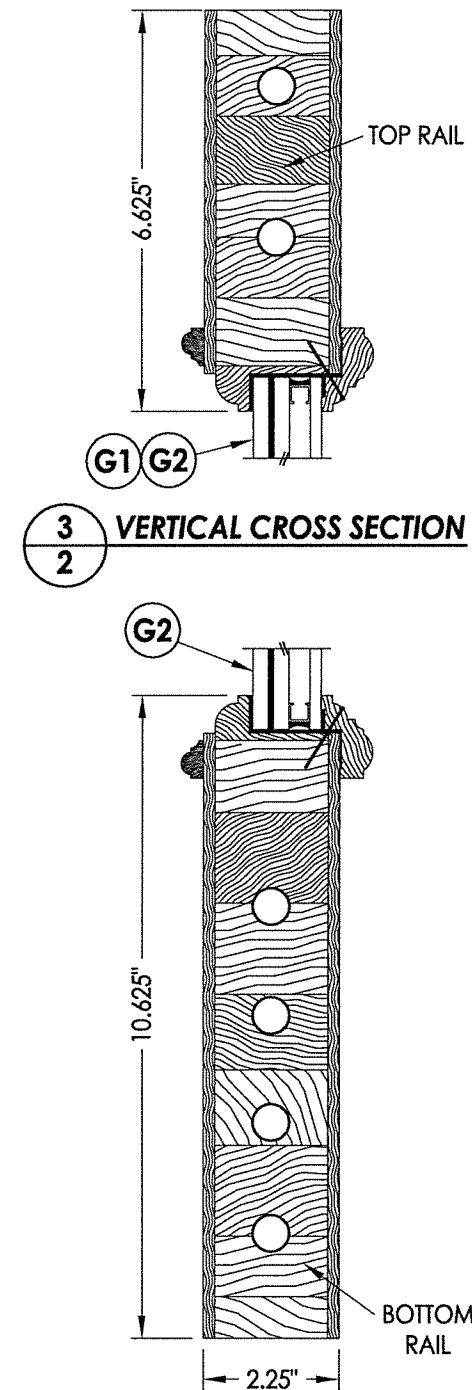

5
2 VERTICAL CROSS SECTION

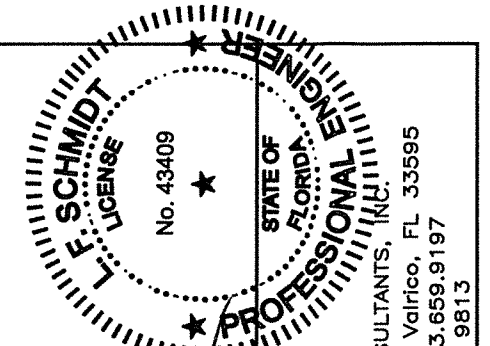

October 12, 2017

Documents Prepared By:
Lyndon F. Schmidt
P.E. No. 43409

RW BUILDING CONSULTANTS, INC.
P.O. Box 230, Vairico, FL 33595
Phone No.: 813.659.9197
FBPE C.A. No. 9813

PRODUCT:	SOUTHEASTERN SASH & DOOR WOOD DOOR
PART OR ASSEMBLY:	DOOR PANEL DETAILS

NO.	DATE	REVISIONS
1	10/12/17	UPDATE TO 6TH ED. (2017) FBC
		LFS
		BY

DATE:	5/10/17
SCALE:	N.T.S.
DWG. BY:	JK
CHK. BY:	LFS
DRAWING NO.:	FL-22347.10
SHEET	2 OF 13

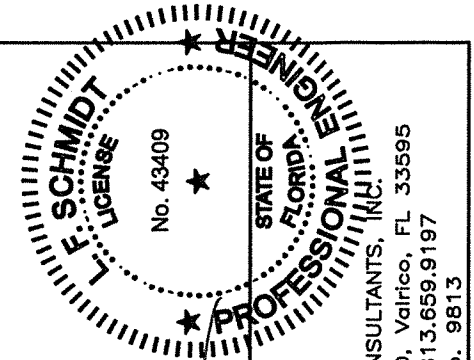

October 12, 2017
 Documents Prepared By:
 Lyndon F. Schmidt
 P.E. No. 43409

R.W. BUILDING CONSULTANTS, INC.
 P.O. Box 230, Vairico, FL 33595
 Phone No.: 813.659.9197
 FBPE C.A. No. 9813

PRODUCT:
 SOUTHEASTERN SASH & DOOR
 WOOD DOOR

PART OR ASSEMBLY:
 DOOR PANEL
 DETAILS

NO.	DATE	REVISIONS	BY
1	10/12/17	UPDATE TO 6TH ED. (2017) FBC	LFS

DATE: 5/10/17
 SCALE: N.T.S.
 DWG. BY: JK
 CHK. BY: LFS
 DRAWING NO.: FL-22347.10
 SHEET 3 OF 13

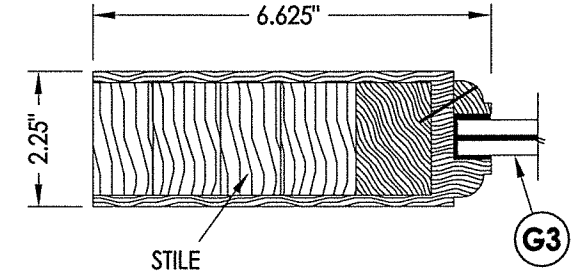

1
3 HORIZONTAL CROSS SECTION

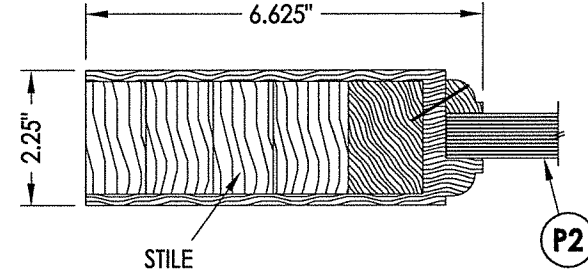

2
3 HORIZONTAL CROSS SECTION

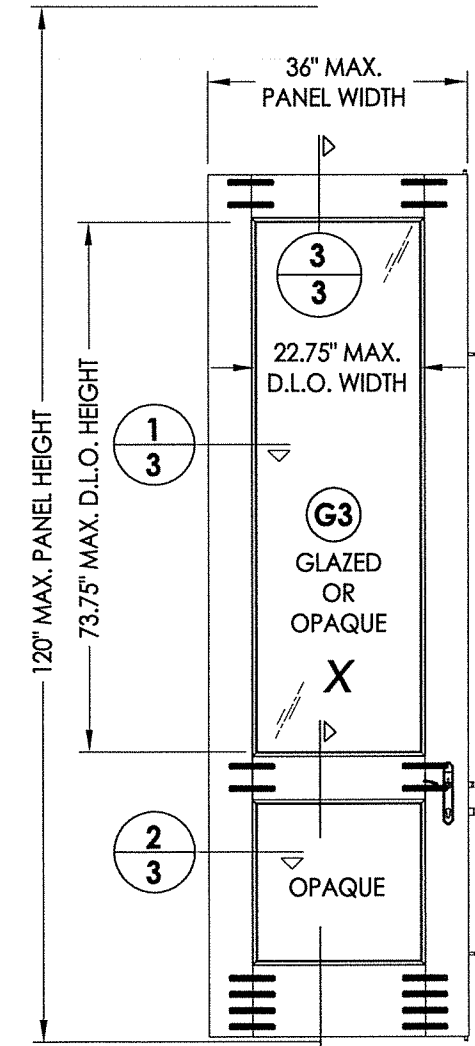

4
3 3/4 PANEL/LITE

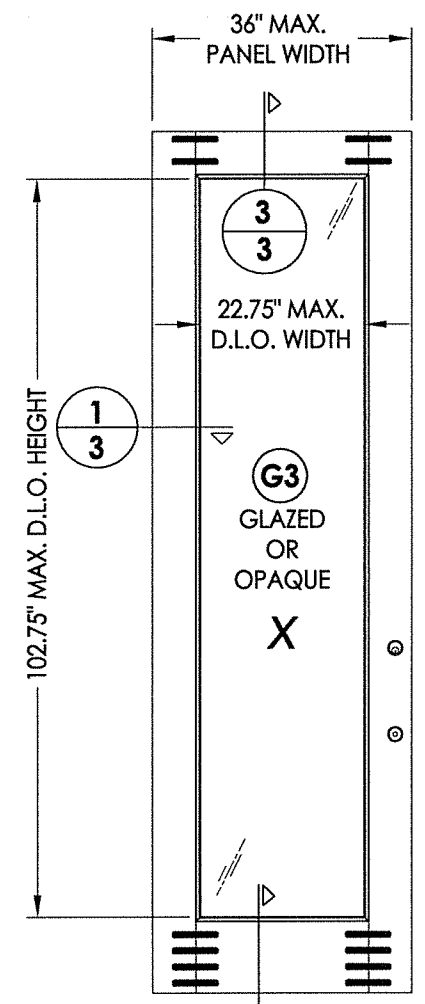

5
3 FULL PANEL/LITE

41 WOOD DOOR PANEL (3'-0")
 Glazed or Opaque

WOOD DOOR COMPONENTS:
 ENGINEERED STAVE CORE: SIPO (UTILE) (G = 0.53)
 VENEER/EDGES: CYPRESS (G = 0.42)
 NOTE: VENEER/EDGE MAY INCLUDE OAK, CHERRY, WALNUT OR
 OTHER OPTIONAL HARDWOOD SPECIES w/ G >= 0.42.

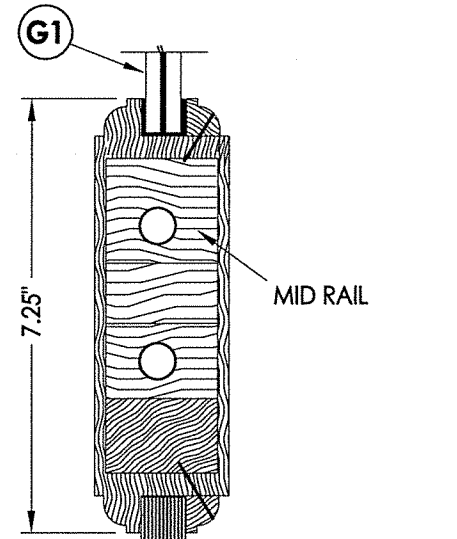

3
3 VERTICAL CROSS SECTION

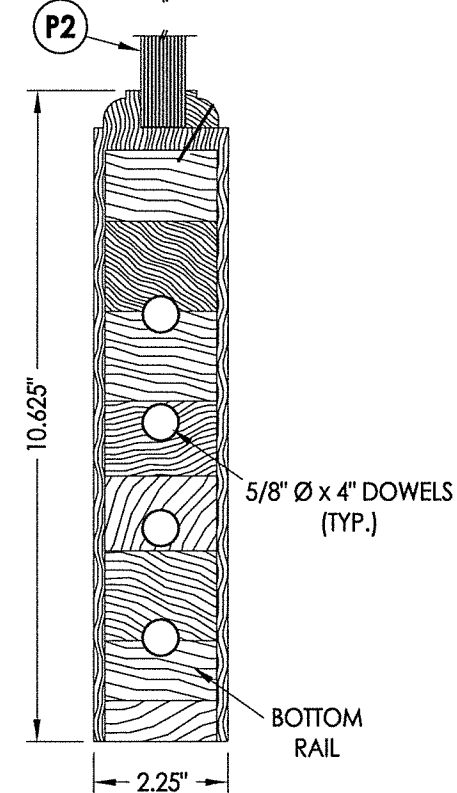

4
3 VERTICAL CROSS SECTION

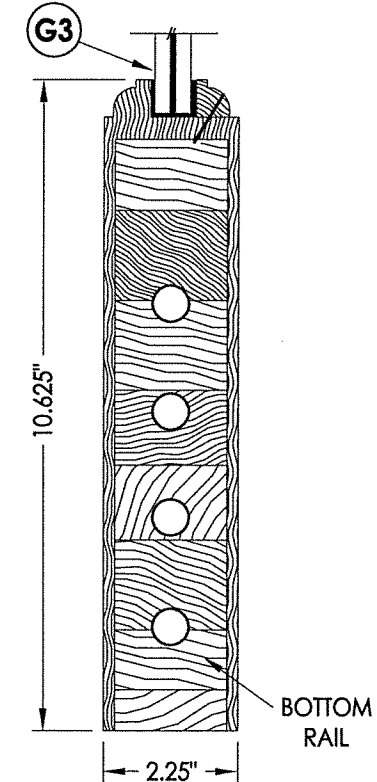
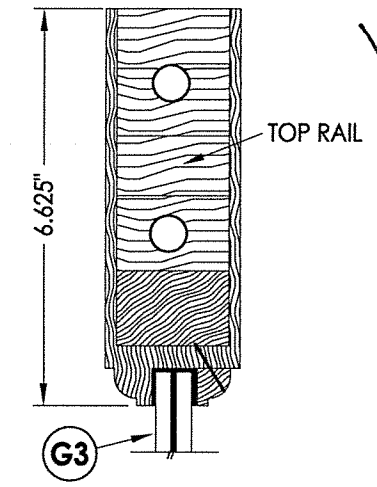

5
3 VERTICAL CROSS SECTION

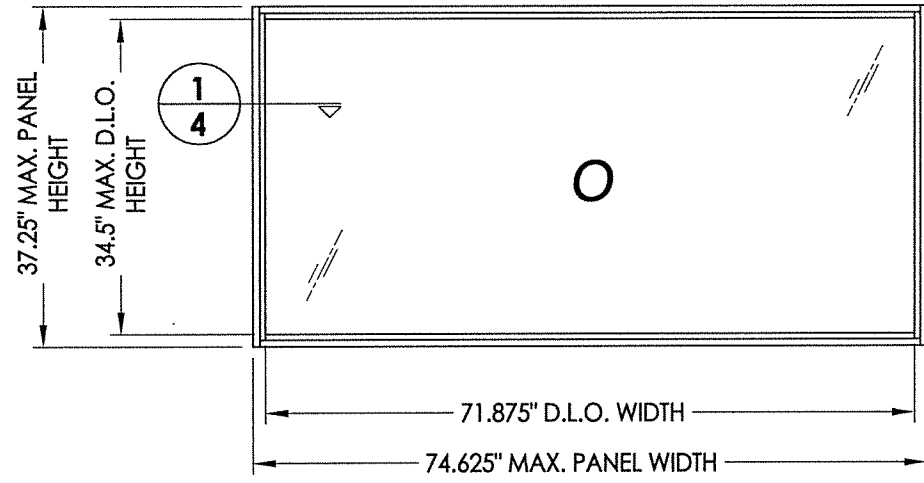

70 WOOD TRANSOM PANEL
DIRECT SET

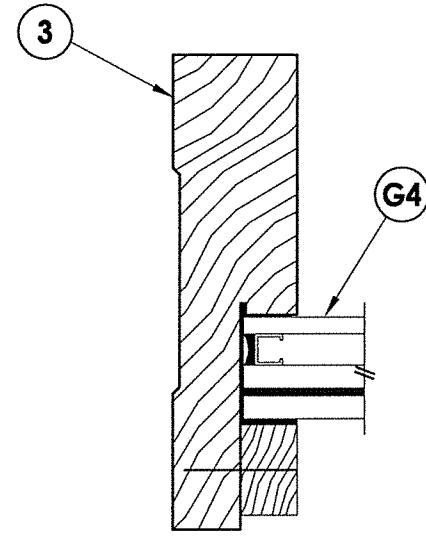

1 HORIZONTAL CROSS SECTION
4

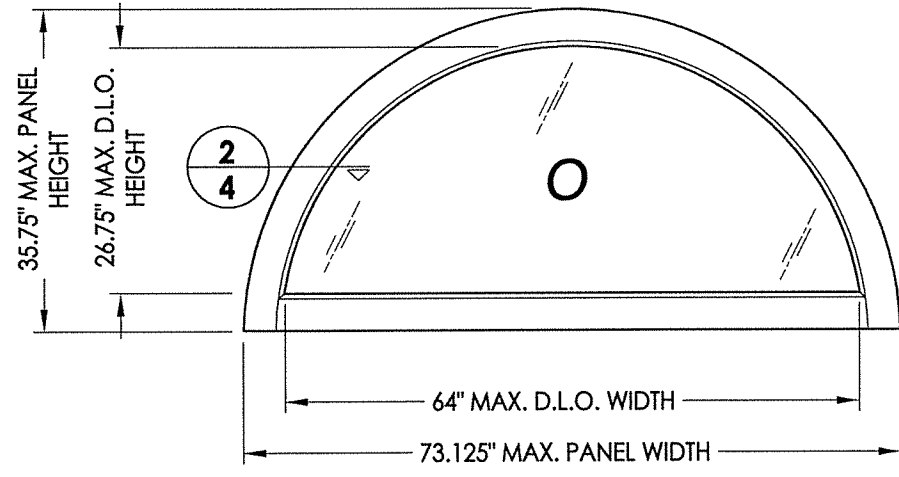

71 WOOD TRANSOM PANEL

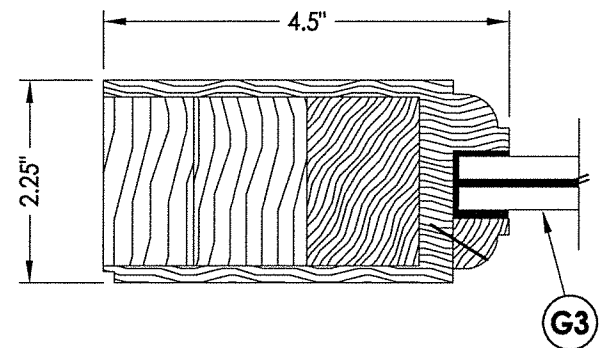
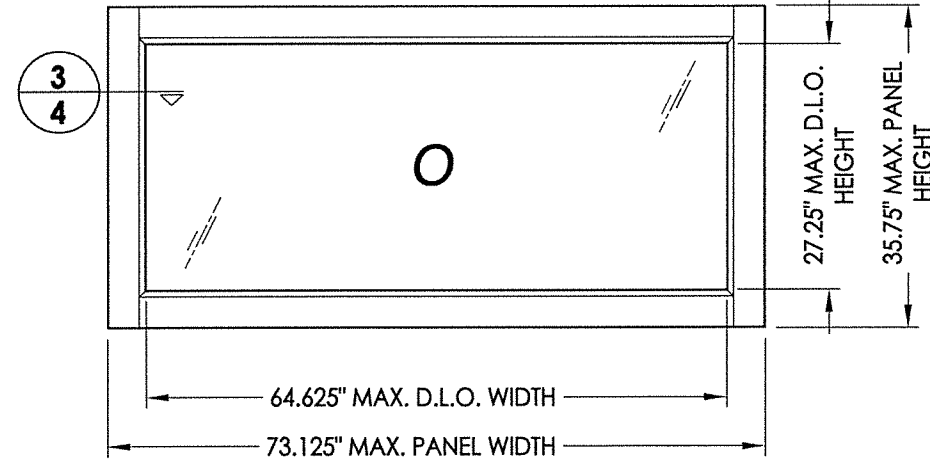

2 HORIZONTAL CROSS SECTION
4

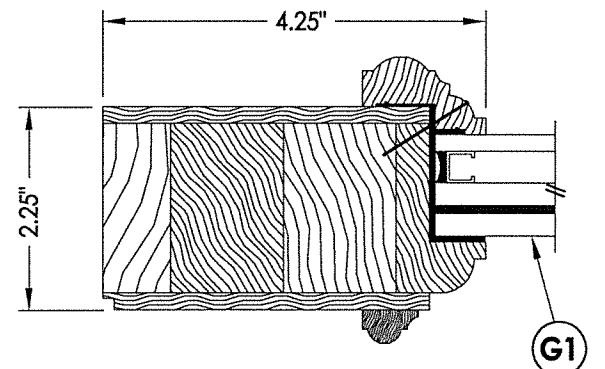

3 HORIZONTAL CROSS SECTION
4

NOTE:
1. ALL FRAME CORNERS SECURED WITH (1) 1/4" X 6" LAG SCREW.

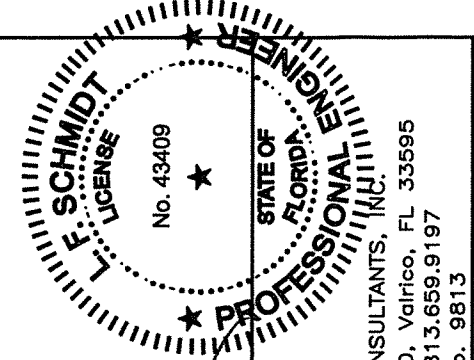

October 12, 2017
 Documents Prepared By:
 Lyndon F. Schmidt
 P.E. No. 43409
 R.W. BUILDING CONSULTANTS, INC.
 P.O. Box 230, Valrico, FL 33595
 Phone No.: 813.659.9197
 FBPE C.A. No. 9813

PRODUCT:		SOUTHEASTERN SASH & DOOR WOOD DOOR	
PART OR ASSEMBLY:		TRANSOM PANEL DETAILS	
NO.	DATE	BY	REVISIONS
1	10/12/17	LFS	UPDATE TO 6TH ED. (2017) FBC
DATE:		5/10/17	
SCALE:		N.T.S.	
DWG. BY:		JK	
CHK. BY:		LFS	
DRAWING NO.:		FL-22347.10	
SHEET		4 OF 13	

R:\Clients\Southeastern Sash & Door\VA - Florida Product Approvals\FL-22347\C - Drawings\FL 22347 (2017)\FL-22347.9-11.dwg, 10.5

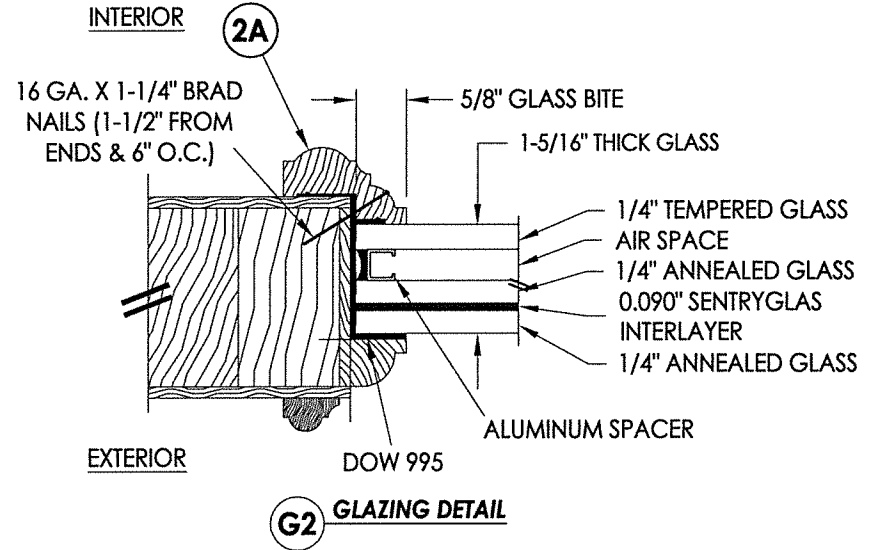
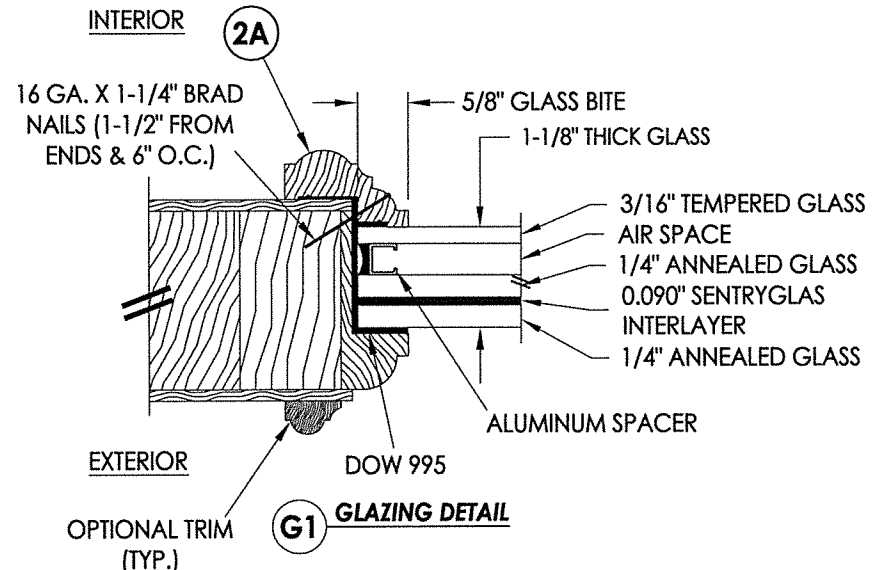

NOTE: GLAZING > 36\"/>

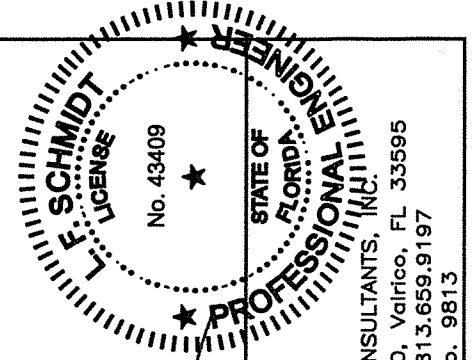
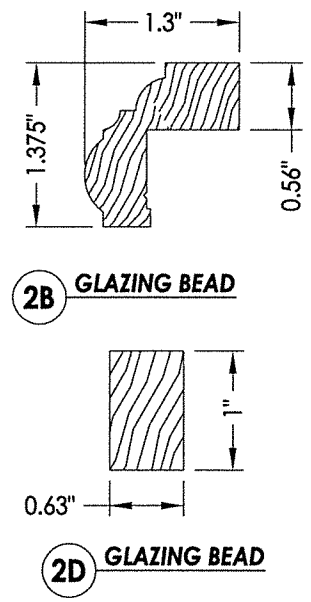
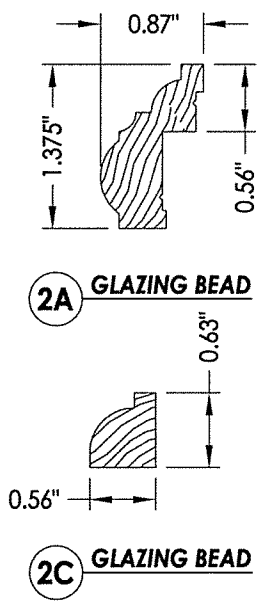
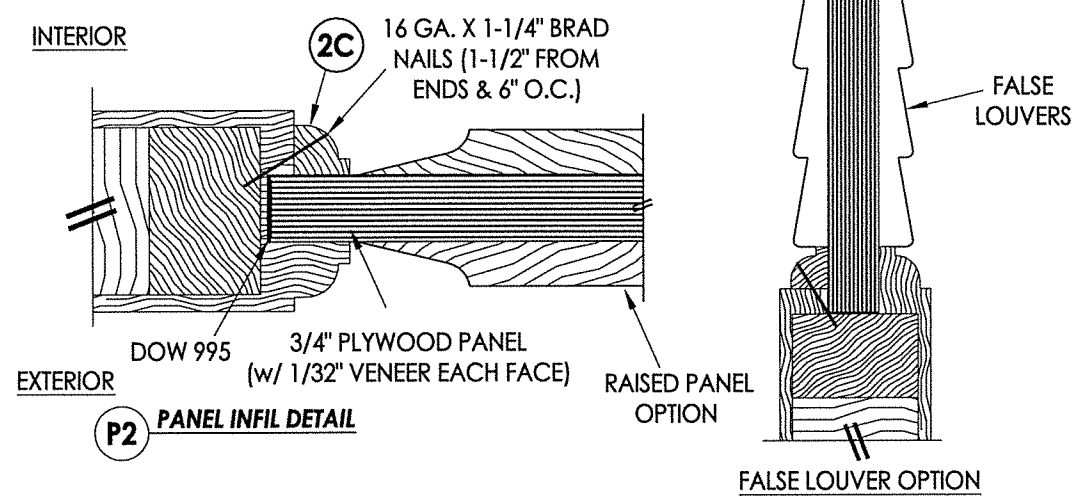
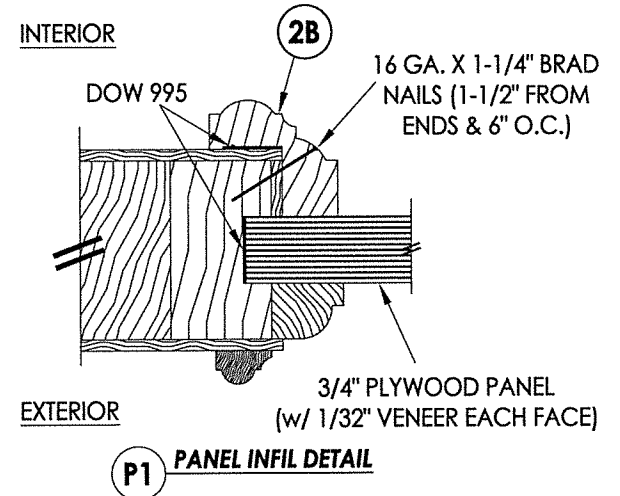
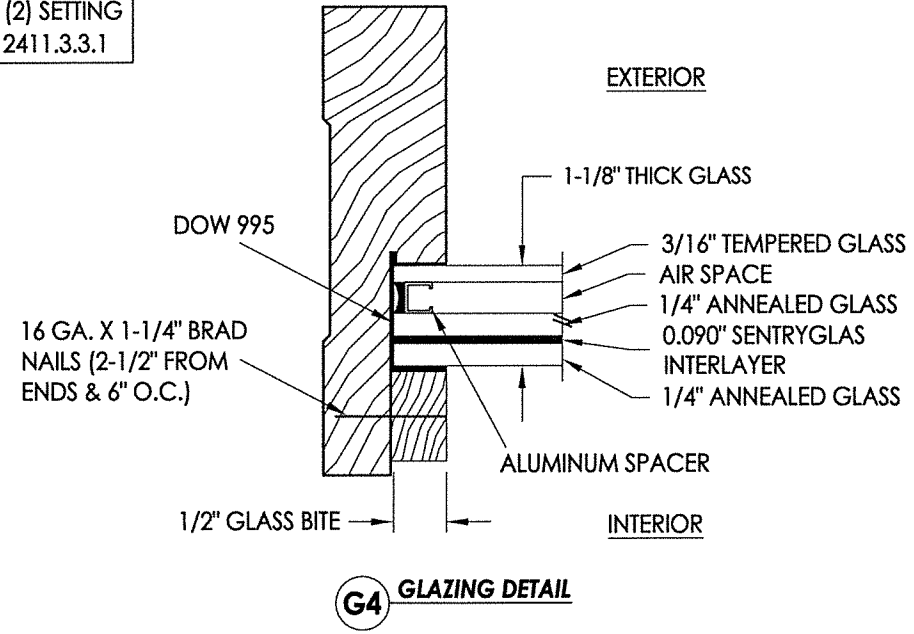
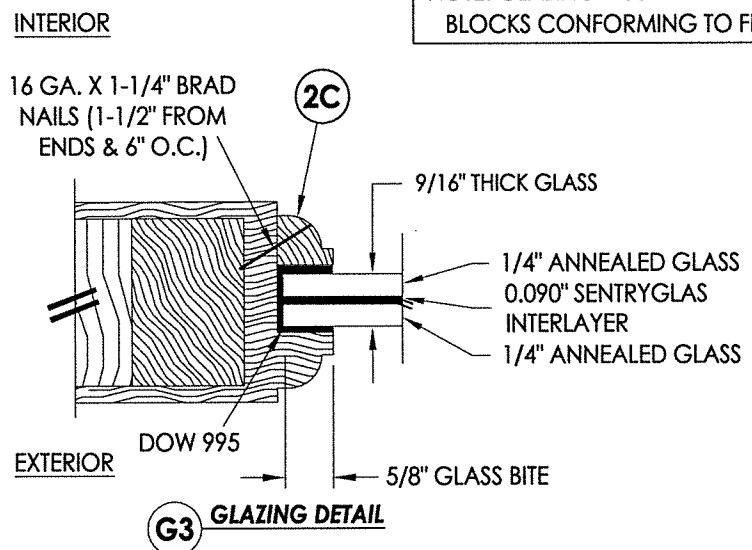

October 12, 2017
 Documents Prepared By:
 Lyndon F. Schmidt
 P.E. No. 43409
 R.W. BUILDING CONSULTANTS, INC.
 P.O. Box 230, Valrico, FL 33595
 Phone No.: 813.659.9197
 FBPE C.A. No. 9813

PRODUCT: SOUTHEASTERN SASH & DOOR WOOD DOOR
 PART OR ASSEMBLY: GLAZING & PANEL INFIL DETAILS

NO.	DATE	DESCRIPTION	BY
1	10/12/17	UPDATE TO 6TH ED. (2017) FBC	LFS

DATE: 5/10/17
 SCALE: N.T.S.
 DWG. BY: JK
 CHK. BY: LFS
 DRAWING NO.: FL-22347.10
 SHEET 5 OF 13

© 2017 R.W. BUILDING CONSULTANTS INC.

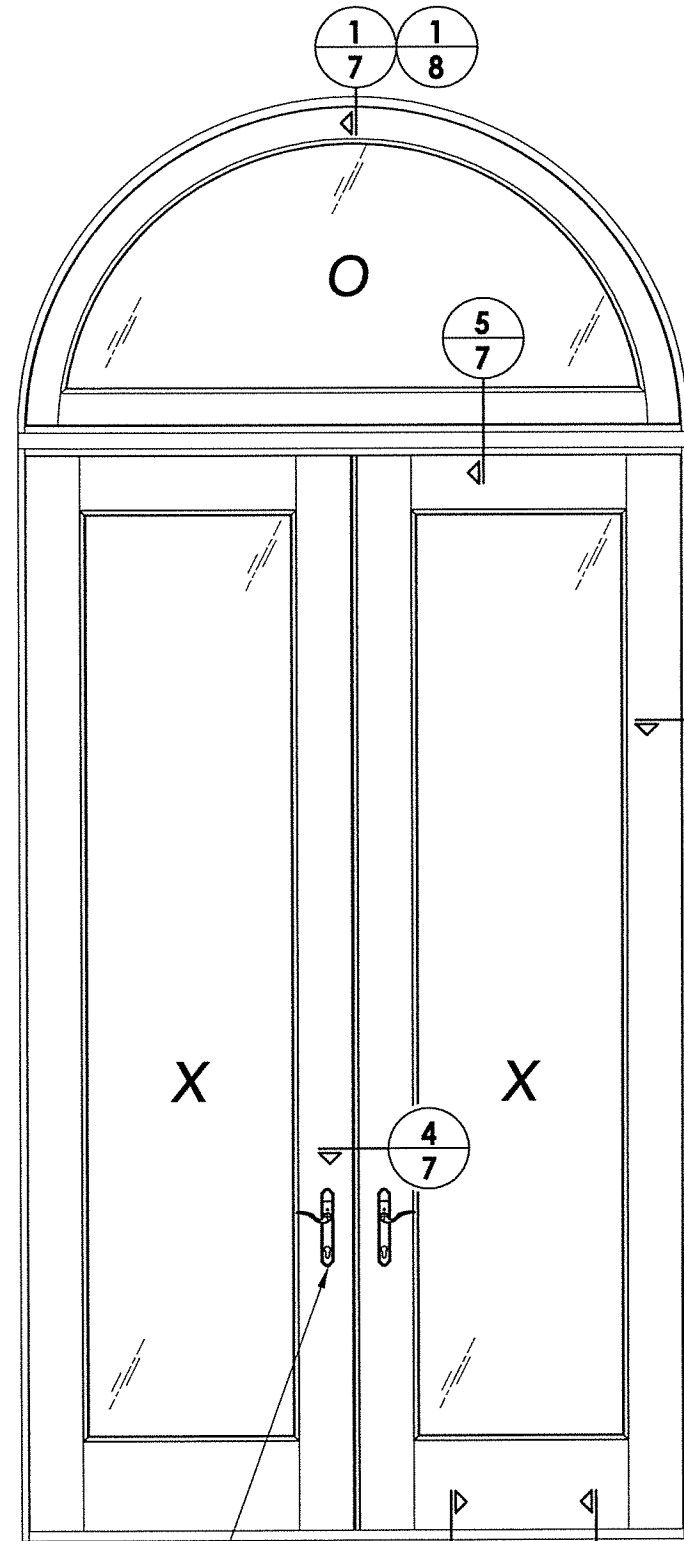

SEE HARDWARE CHART

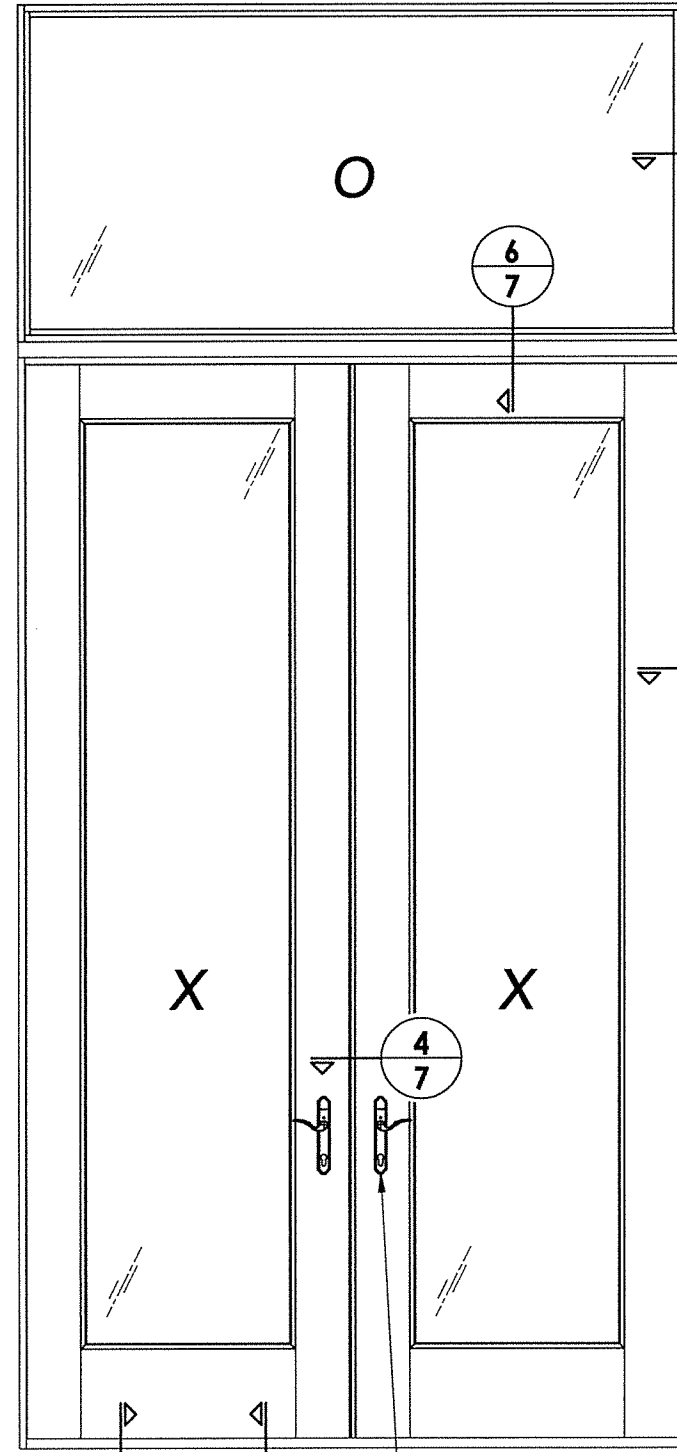
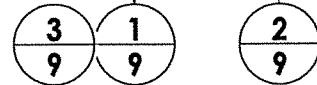

SEE HARDWARE CHART

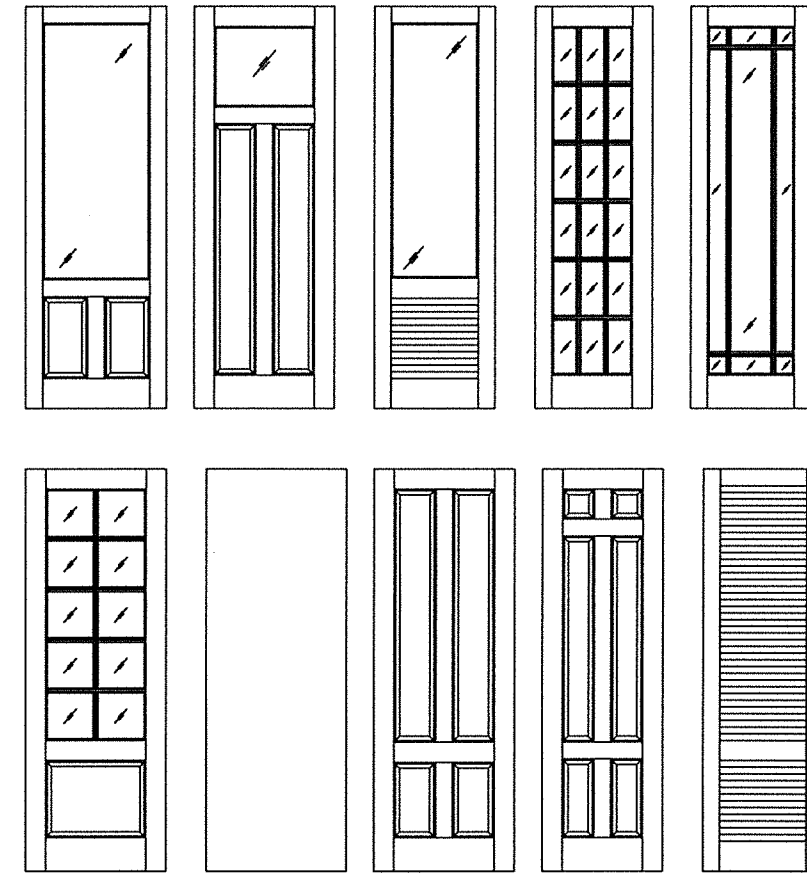
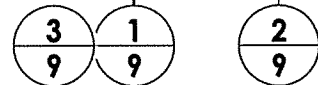

SOUTHEASTERN SASH & DOOR Door Panel Options

Panel options shown are for illustration and are representative only. Surface applied muntins are used for simulated divided lites shown.

HARDWARE TABLE	
MANUFACTURER	MODEL
HOPPE	MULTIPOINT HARDWARE: HLS 9000 SERIES MULTIPOINT LOCK ACTIVE: ROUNDBOLT/SHOOTBOLT (5-PT.) INACTIVE: SHOOTBOLT (2-PT.)

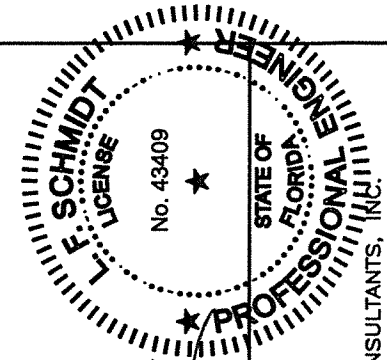

October 12, 2017
 Documents Prepared By:
 Lyndon F. Schmidt
 P.E. No. 43409

RW BUILDING CONSULTANTS, INC.
 P.O. Box 230, Vairico, FL 33595
 Phone No.: 813.659.9197
 FBPE C.A. No. 9813

PRODUCT: SOUTHEASTERN SASH & DOOR WOOD DOOR
 PART OR ASSEMBLY: ELEVATIONS

NO.	DATE	REVISIONS
1	10/12/17	UPDATE TO 6TH ED. (2017) FBC
		LFS
		BY

DATE: 05/10/17
 SCALE: N.T.S.
 DWG. BY: JK
 CHK. BY: LFS
 DRAWING NO.: FL-22347.10
 SHEET 6 OF 13

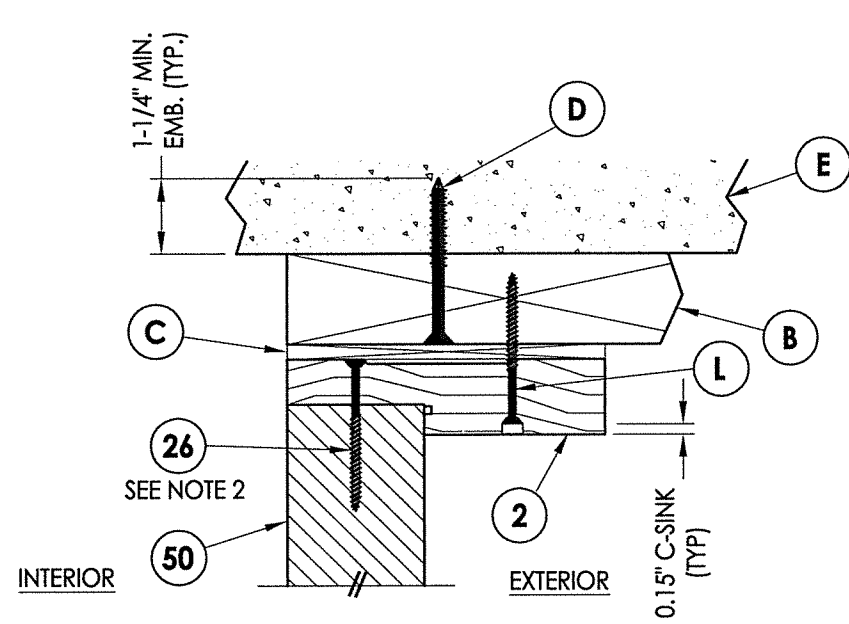

1 VERTICAL CROSS SECTION
7 Shown w/ 2X Buck
 Inswing shown (Outswing similar)

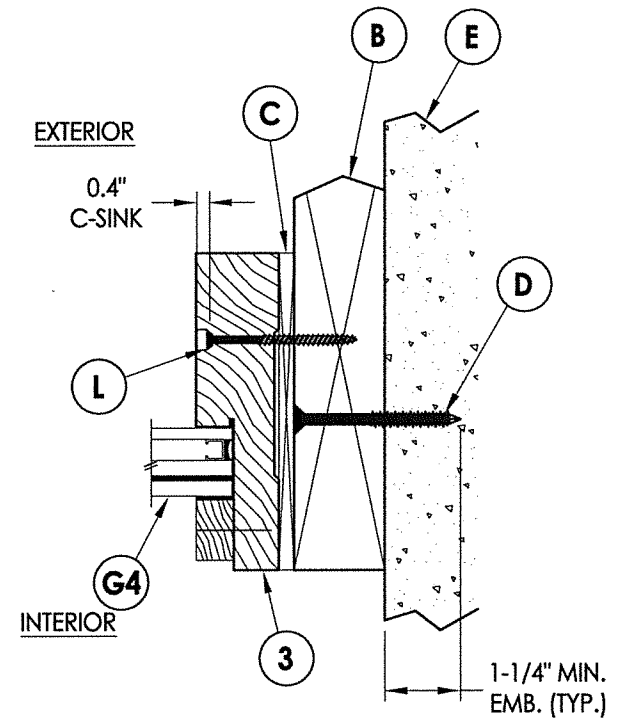

2 HORIZONTAL CROSS SECTION
7 Shown w/ 2X Buck
 Inswing shown (Outswing similar)

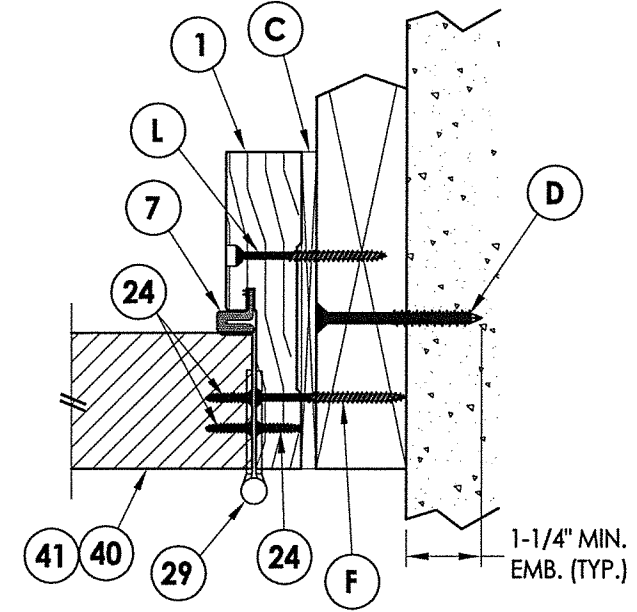

3 HORIZONTAL CROSS SECTION
7 Shown w/ 2X Buck
 Inswing shown (Outswing similar)

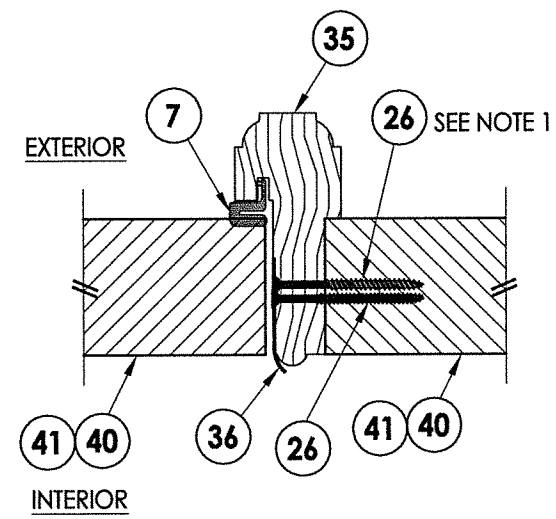

4 HORIZONTAL CROSS SECTION
7 Inswing shown (Outswing similar)

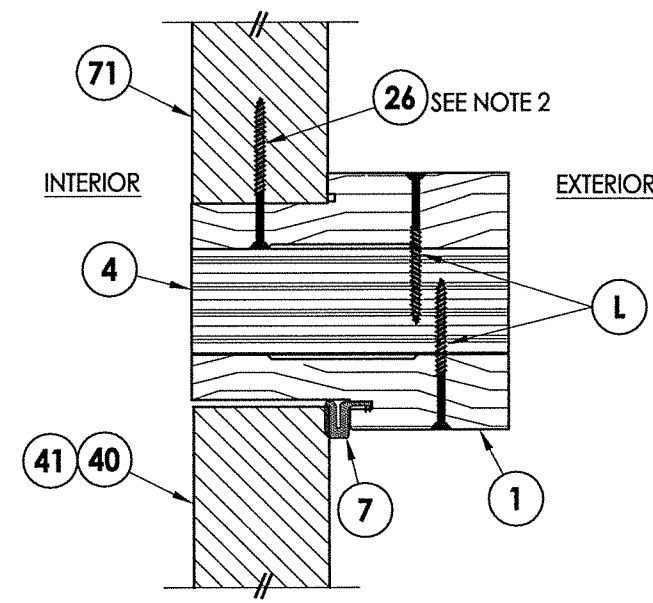

5 VERTICAL CROSS SECTION
7 Inswing shown (Outswing similar)

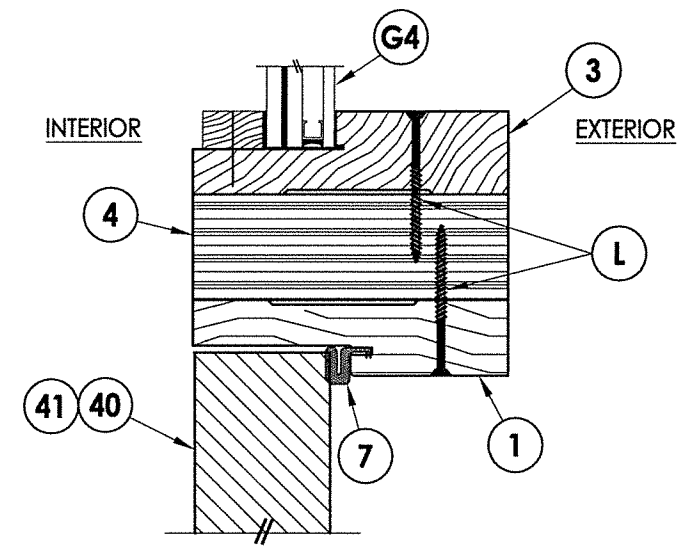

6 VERTICAL CROSS SECTION
7 Inswing shown (Outswing similar)

NOTES:
 1. Item #26 located 4" from each end & 9 more equally spaced (11 total).
 2. Item #26 located 4" from each end & 1 at the center line (3 total).

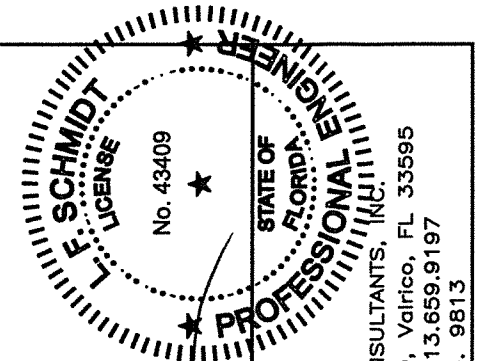

October 12, 2017
 Documents Prepared By:
 Lyndon F. Schmidt
 P.E. No. 43409
 R.W. BUILDING CONSULTANTS, INC.
 P.O. Box 230, Valrico, FL 33595
 Phone No.: 813.659.9197
 FBPE C.A. No. 9813

PRODUCT:
 SOUTHEASTERN SASH & DOOR
 WOOD DOOR
 PART OR ASSEMBLY:
 HORIZONTAL & VERTICAL
 CROSS SECTIONS (2X BUCK)

NO.	DATE	BY
1	10/12/17	LFS
UPDATE TO 6TH ED. (2017) FBC		

DATE: 5/10/17
 SCALE: N.T.S.
 DWG. BY: JK
 CHK. BY: LFS
 DRAWING NO.: FL-22347.10
 SHEET 7 OF 13

NOTES:
 1. Item #26 located 4" from each end & 1 at the center line (3 total).

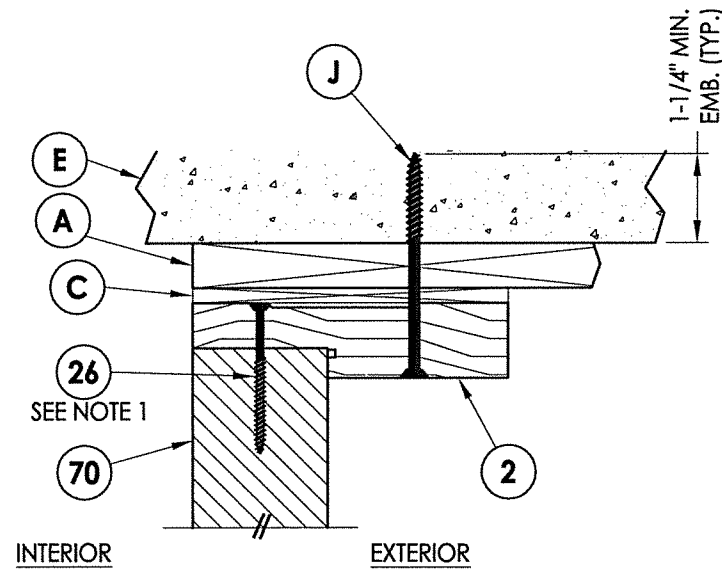

1
8 **VERTICAL CROSS SECTION**
 Shown w/ 1X Buck
 Inswing shown (Outswing similar)

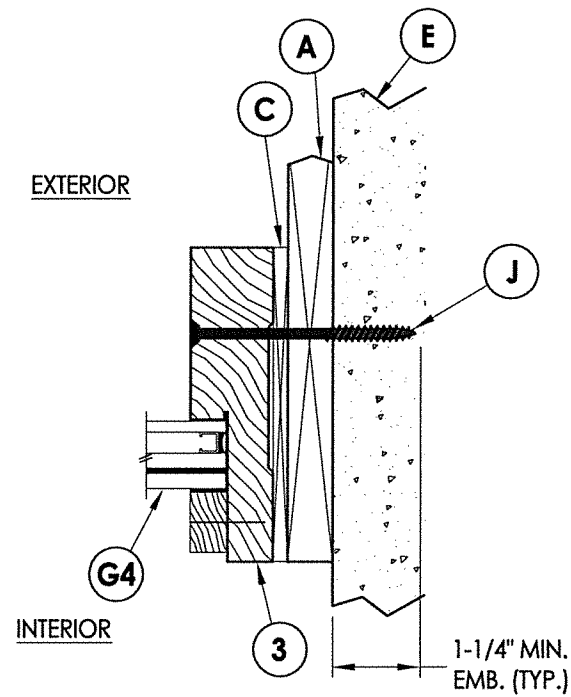

2
8 **HORIZONTAL CROSS SECTION**
 Shown w/ 1X Buck
 Inswing shown (Outswing similar)

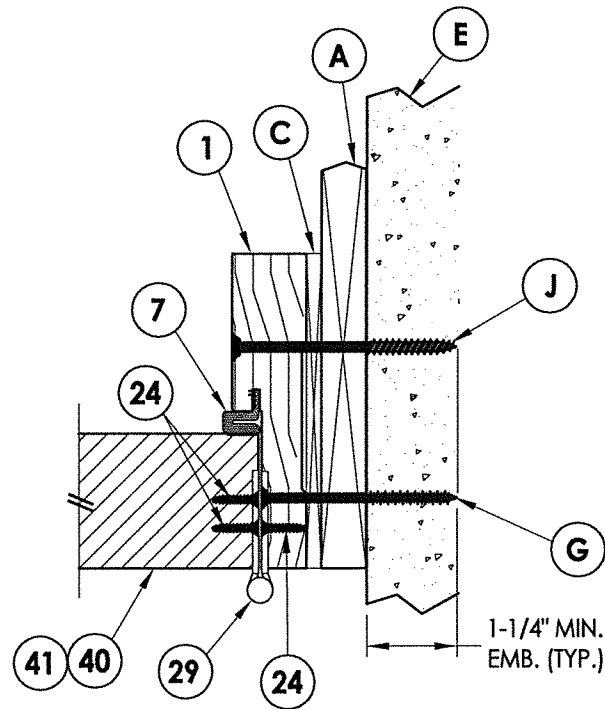

3
8 **HORIZONTAL CROSS SECTION**
 Shown w/ 1X Buck
 Inswing shown (Outswing similar)

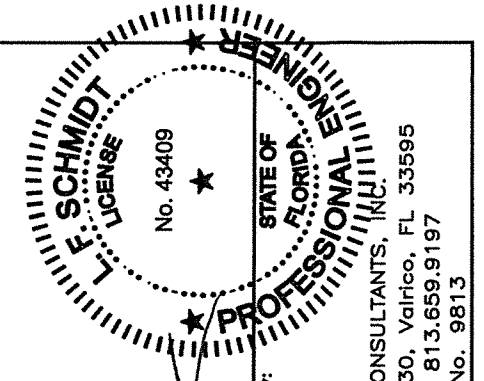

October 12, 2017
 Documents Prepared By:
 Lyndon F. Schmidt
 P.E. No. 43409

RW BUILDING CONSULTANTS, INC.
 P.O. Box 230, Valrico, FL 33595
 Phone No.: 813.659.9197
 FBPE C.A. No. 9813

PRODUCT:
 SOUTHEASTERN SASH & DOOR
 WOOD DOOR

PART OR ASSEMBLY:
 HORIZONTAL & VERTICAL
 CROSS SECTIONS (1X BUCK)

NO.	DATE	DESCRIPTION	BY
1	10/12/17	UPDATE TO 6TH ED. (2017)	LFS

DATE: 5/10/17
 SCALE: N.T.S.
 DWG. BY: JK
 CHK. BY: LFS
 DRAWING NO.: FL-22347.10
 SHEET 8 OF 13

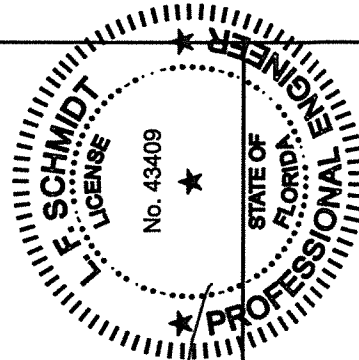

October 12, 2017
 Documents Prepared By:
 Lyndon F. Schmidt
 P.E. No. 43409

RW BUILDING CONSULTANTS, INC.
 P.O. Box 230, Valrico, FL 33595
 Phone No.: 813.659.9197
 FBPE C.A. No. 9813

PRODUCT:
 SOUTHEASTERN SASH & DOOR
 WOOD DOOR

PART OR ASSEMBLY:
 VERTICAL CROSS
 SECTIONS (THRESHOLD)

NO.	DATE	BY	REVISIONS
1	10/12/17	FBC	UPDATE TO 6TH ED. (2017)
		LFS	

DATE: 5/10/17
 SCALE: N.T.S.
 DWG. BY: JK
 CHK. BY: LFS
 DRAWING NO.: FL-22347.10
 SHEET 9 OF 13

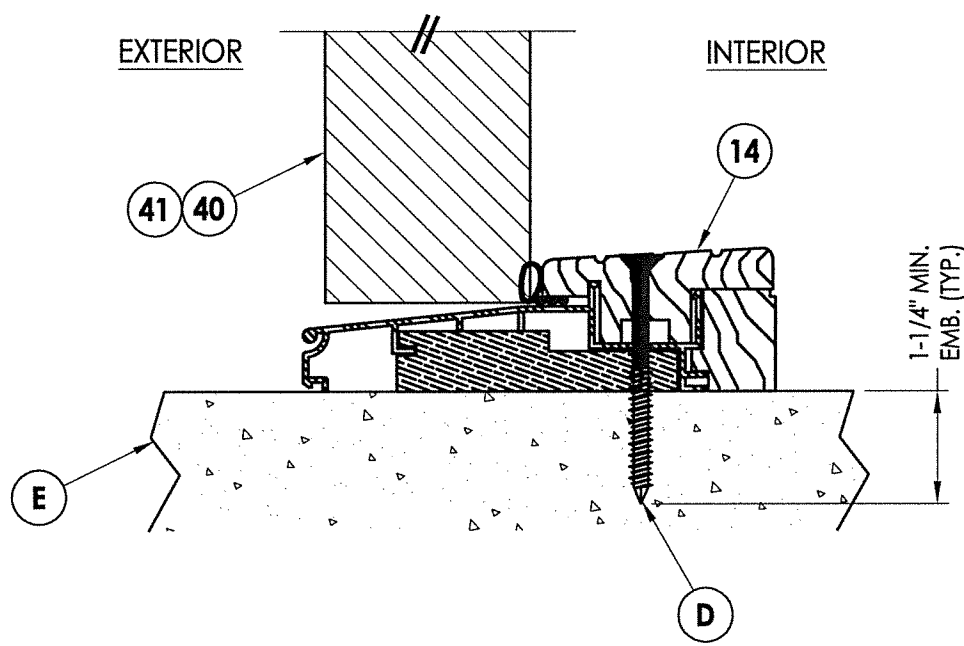

1 VERTICAL CROSS SECTION
9 Outswing

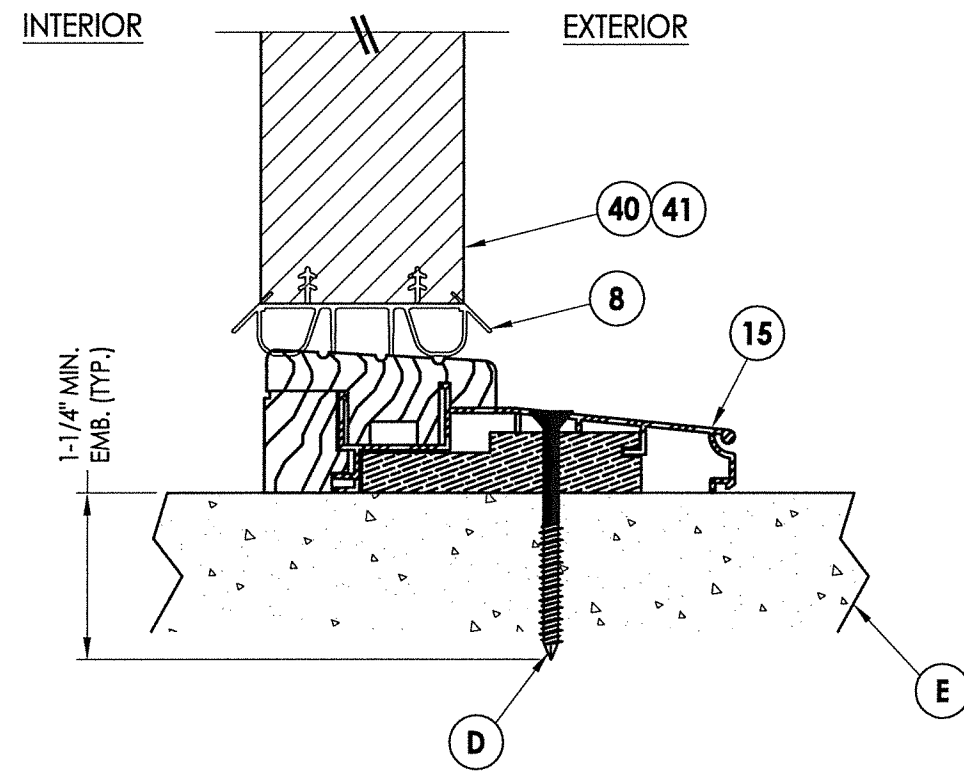

2 VERTICAL CROSS SECTION
9 Inswing

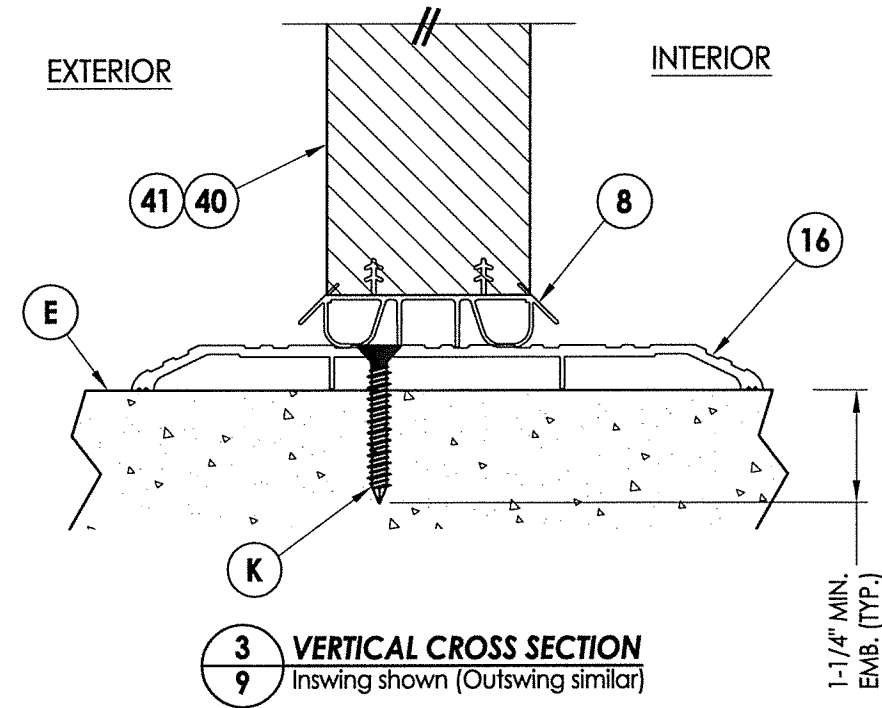

3 VERTICAL CROSS SECTION
9 Inswing shown (Outswing similar)

R:\Clients\Southeastern Sash & Door\A - Florida Product Approvals\FL-22347C - Drawings\FL 22347 (2017)\FL-22347.9-11.dwg, 10.10

2X FRAMING (No. 2 SYP) ATTACHED w/
(2) #10 x 3" WOOD SCREWS @ EACH
END (TYP.)

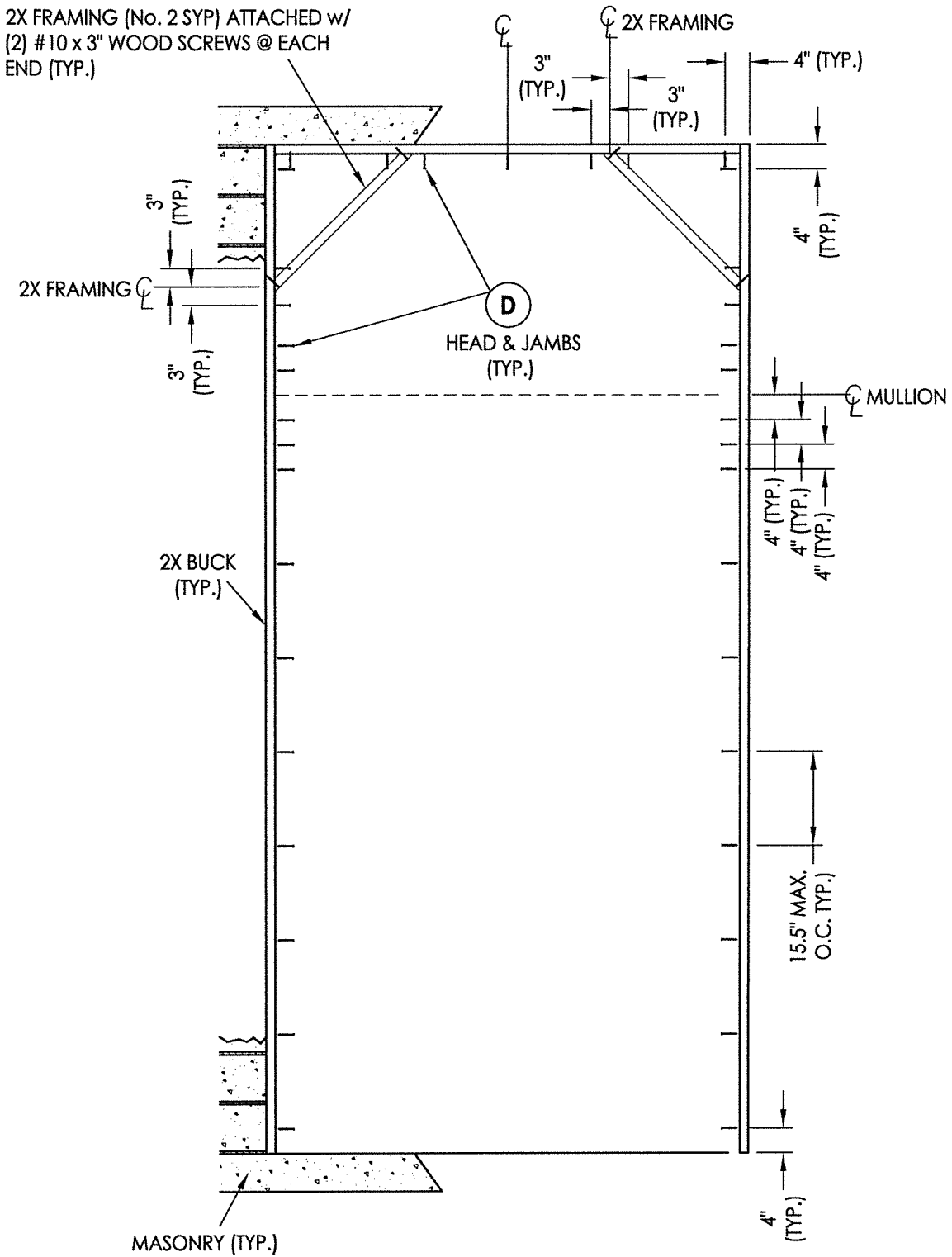

2X BUCK ANCHORING
O/XX (Arch Top Transom)

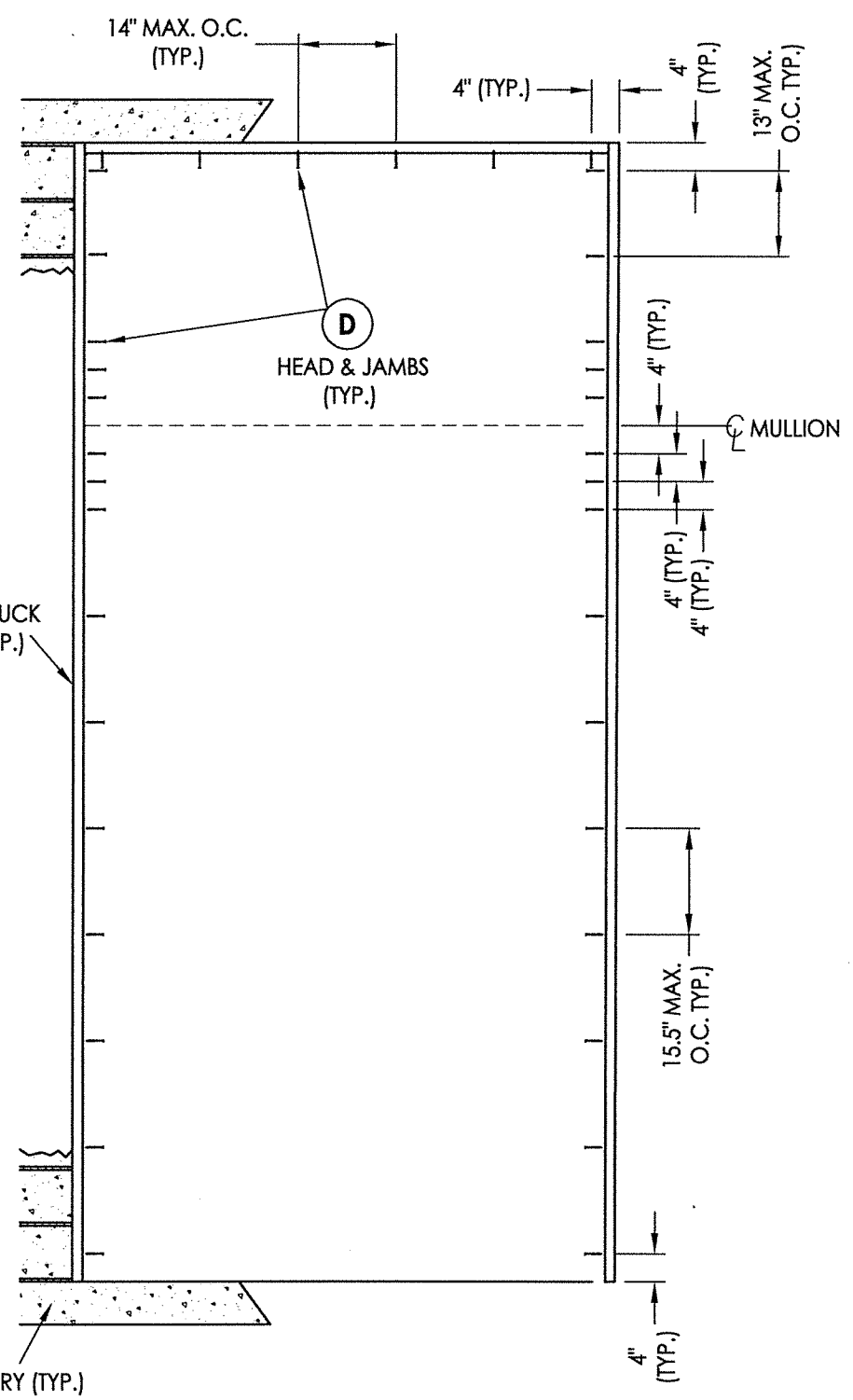

2X BUCK ANCHORING
O/XX

NOTE:
1. ALL FRAME CORNERS SECURED WITH (3) #8 X 2-1/2" FH
DEEP THREAD WOOD SCREWS @ SILL.

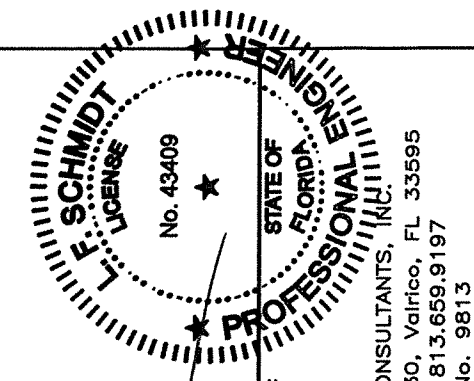

October 12, 2017
Documents Prepared By:
Lyndon F. Schmidt
P.E. No. 43409
RW BUILDING CONSULTANTS, INC.
P.O. Box 230, Vairico, FL 33595
Phone No.: 813.659.9197
FBPE C.A. No. 9813

PRODUCT:
SOUTHEASTERN SASH & DOOR
WOOD DOOR
PART OR ASSEMBLY:
BUCK ANCHORING

NO.	DATE	DESCRIPTION	BY
1	10/12/17	UPDATE TO 6TH ED. (2017)	LFS

DATE: 5/10/17
SCALE: N.T.S.
DWG. BY: JK
CHK. BY: LFS
DRAWING NO.: FL-22347.10
SHEET 10 OF 13

© 2017 R.W. BUILDING CONSULTANTS INC.

R:\Clients\Southeastern Sash & Door\A - Florida Product Approvals\FL-22347\C - Drawings\FL 22347 (2017)\FL-22347.9-11.dwg, 10.11

NOTE: ANCHORING OF FRAMING TO 1X BUCK IS THE RESPONSIBILITY OF THE BUILDING DESIGNER.

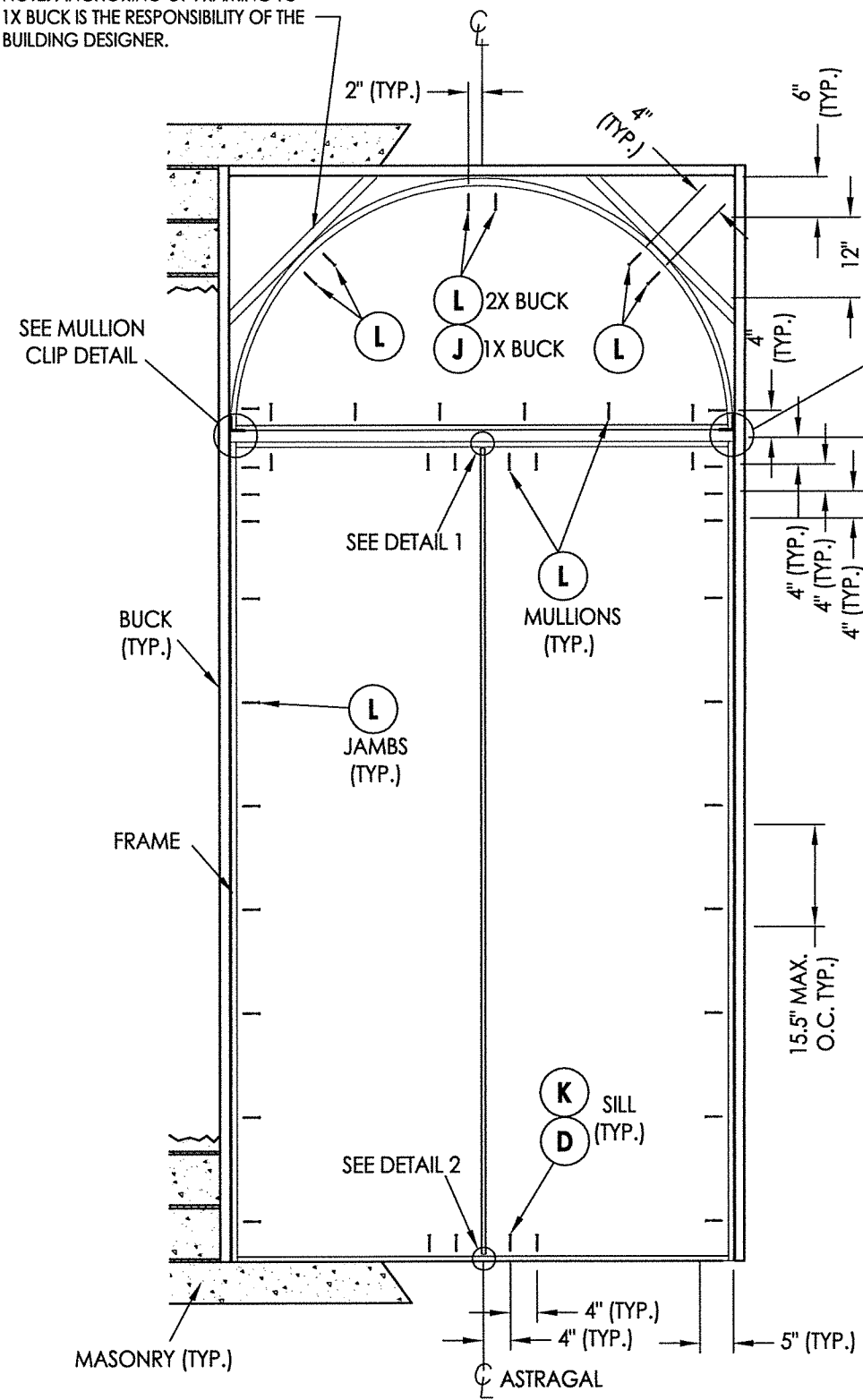

FRAME ANCHORING
O/XX (Arch Top Transom)

NOTE:
1. ALL FRAME CORNERS SECURED WITH (3) #8 X 2-1/2" FH DEEP THREAD WOOD SCREWS @ SILL.

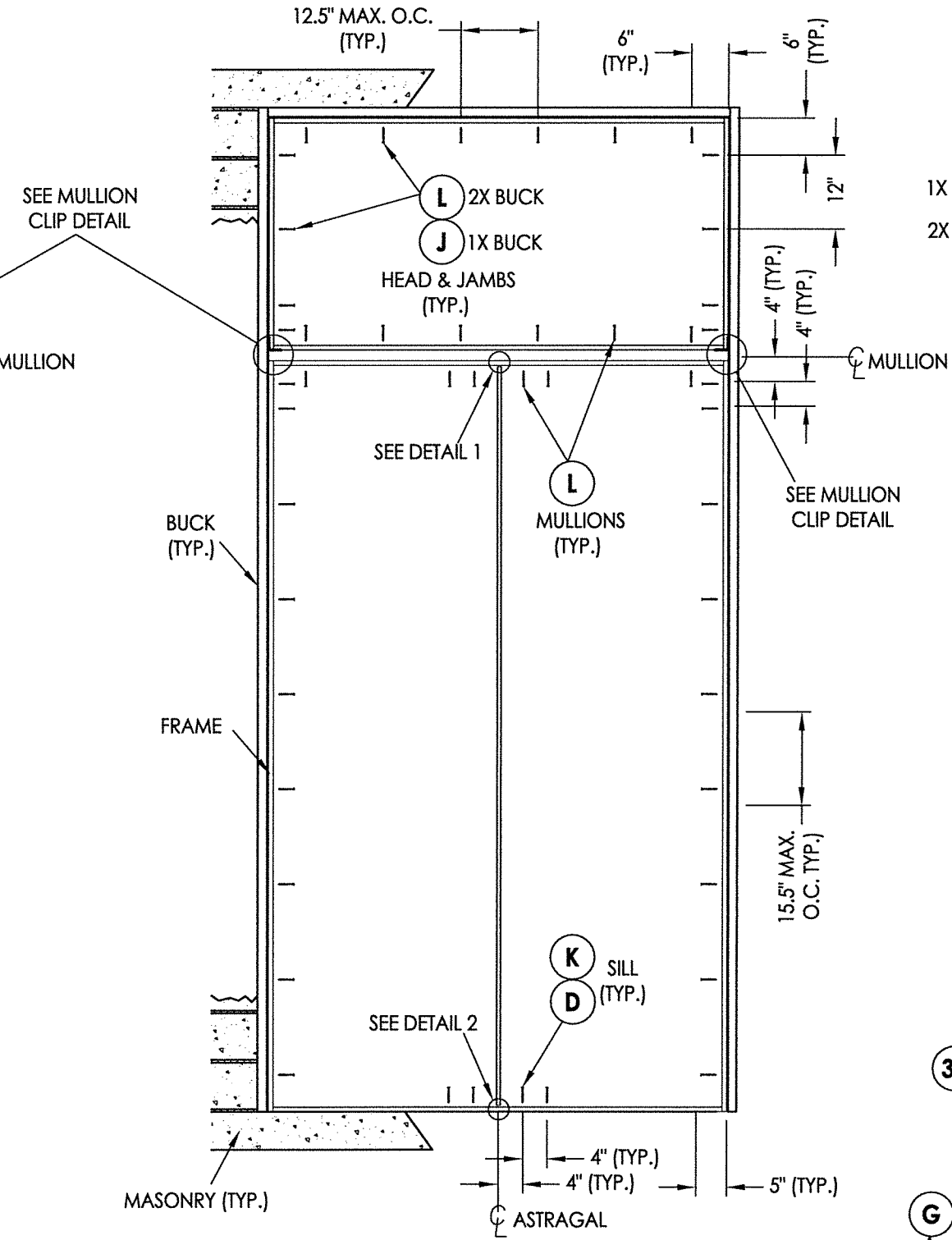

FRAME ANCHORING
O/XX

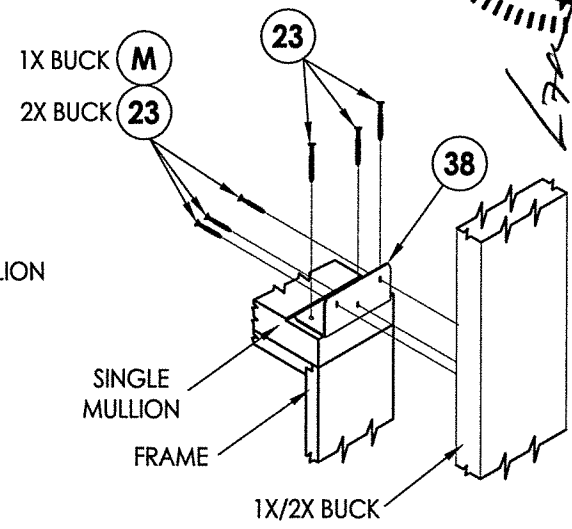

MULLION CLIP DETAIL

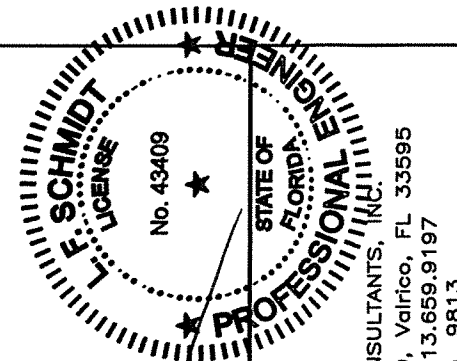
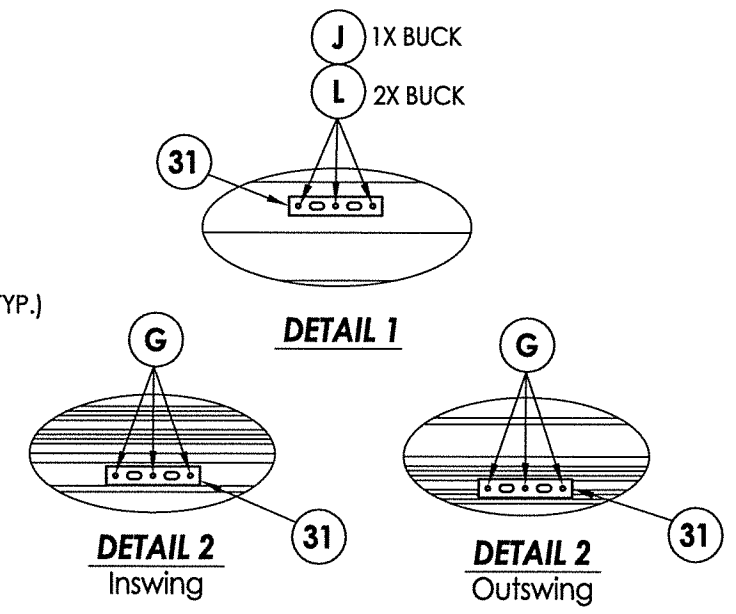

October 12, 2017
 Documents Prepared By:
 Lyndon F. Schmidt
 P.E. No. 43409

PRODUCT:
 SOUTHEASTERN SASH & DOOR
 WOOD DOOR

PART OR ASSEMBLY:
 FRAME ANCHORING

NO.	DATE	DESCRIPTION	BY
1	10/12/17	UPDATE TO 6TH ED. (2017) FBC	LFS

DATE: 5/10/17
 SCALE: N.T.S.
 DWG. BY: JK
 CHK. BY: LFS
 DRAWING NO.: FL-22347.10
 SHEET 11 of 13

RW BUILDING CONSULTANTS, INC.
 P.O. Box 230, Valrico, FL 33595
 Phone No.: 813.659.9197
 FBPE C.A. No. 9813

© 2017 R.W. BUILDING CONSULTANTS INC.

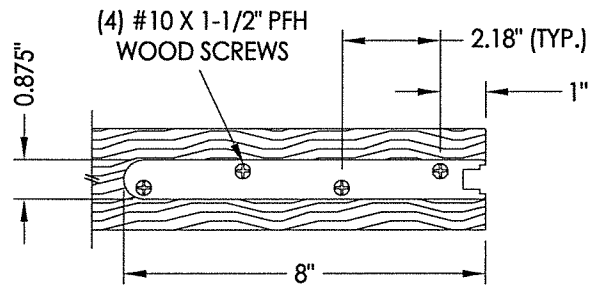

SHOOTBOLT REINFORCMENT
AT TOP & BOTTOM OF DOOR PANEL
(1/8" THICK STEEL)

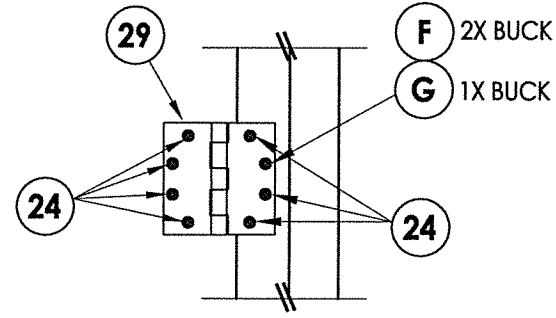

HINGE DETAIL

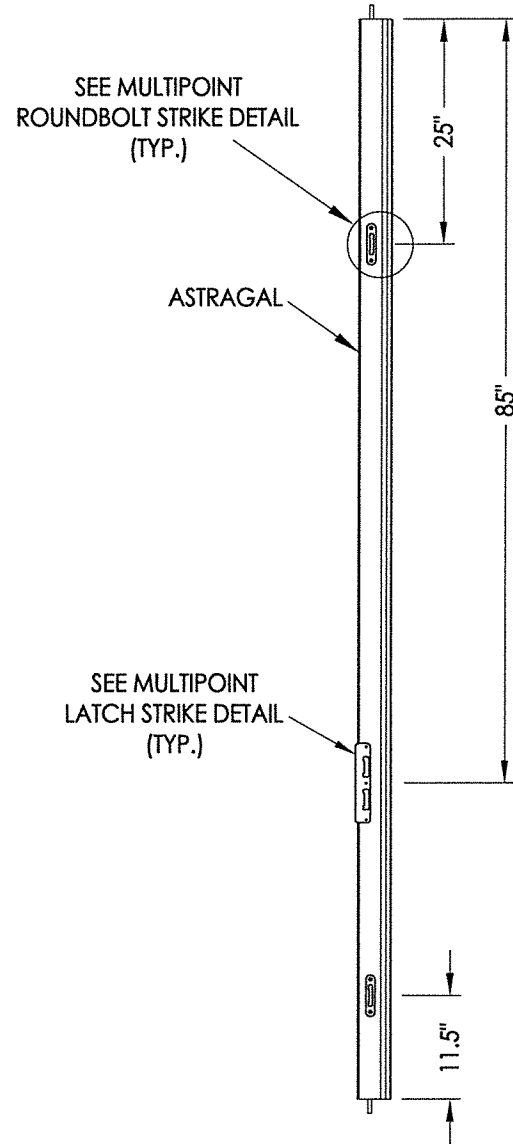

MULTIPOINT LOCK DETAILS

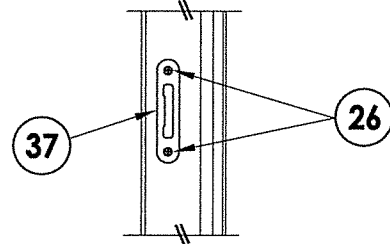

MULTIPOINT ROUND BOLT STRIKE DETAIL

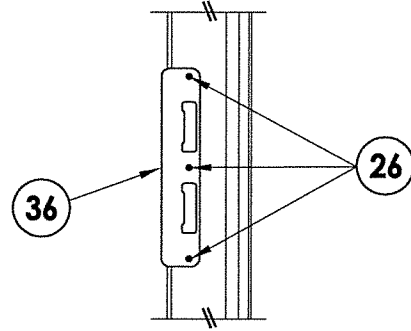

MULTIPOINT STRIKE DETAIL

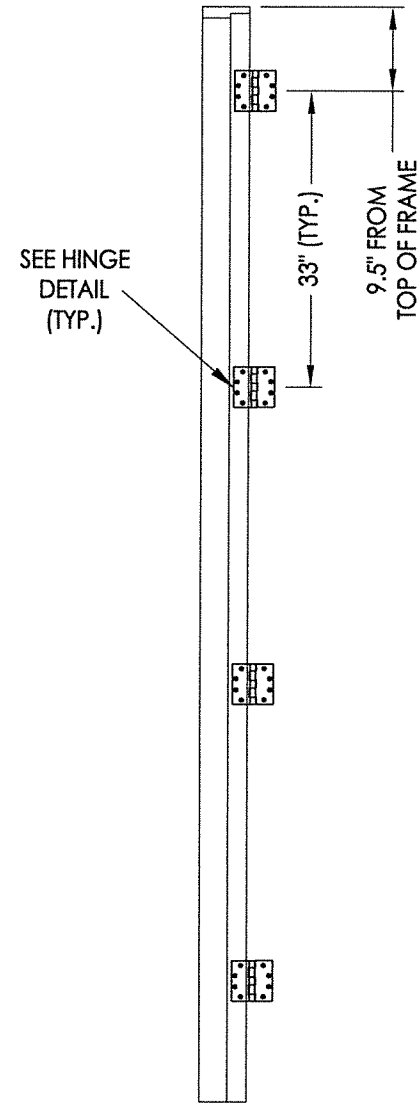

HINGE JAMB

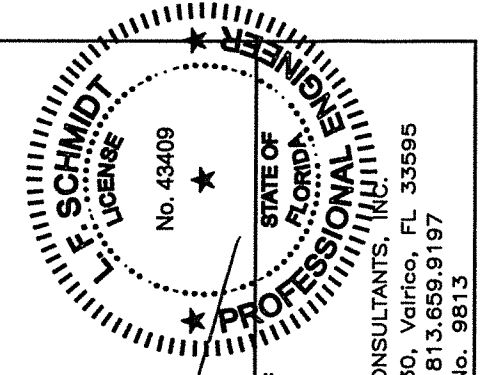

October 12, 2017
 Documents Prepared By:
 Lyndon F. Schmidt
 P.E. No. 43409
 R.W. BUILDING CONSULTANTS, INC.
 P.O. Box 230, Valrico, FL 33595
 Phone No.: 813.659.9197
 FBPE C.A. No. 9813

PRODUCT:
 SOUTHEASTERN SASH & DOOR
 WOOD DOOR
 PART OR ASSEMBLY:
 HARDWARE DETAILS

NO.	DATE	DESCRIPTION	BY
1	10/12/17	UPDATE TO 6TH ED. (2017)	LFS

DATE: 5/10/17
 SCALE: N.T.S.
 DWG. BY: JK
 CHK. BY: LFS
 DRAWING NO.: FL-22347.10
 SHEET 12 OF 13

BILL OF MATERIALS		
ITEM #	DESCRIPTION	MATERIAL
A	1X BUCK (SG >= 0.42)	WOOD
B	2X BUCK (SG >= 0.42)	WOOD
C	1/4" MAX. SHIM SPACE	-
D	1/4" X 2-3/4" PFH ELCO OR ITW CONCRETE SCREW	STEEL
E	MASONRY - 3,000 PSI MIN. CONCRETE CONFORMING TO ACI 301 OR HOLLOW BLOCK CONFORMING TO ASTM C90	CONCRETE
F	#12 X 2-1/2" PFH WOOD SCREW	STEEL
G	3/16" X 3-1/4" PFH ITW CONCRETE SCREW	STEEL
J	1/4" X 3-3/4" PFH ELCO OR ITW CONCRETE SCREW	STEEL
K	1/4" X 1-3/4" PFH ELCO OR ITW CONCRETE SCREW	STEEL
L	#10 X 2-1/2" PFH WOOD SCREW (1.15" MIN. EMBEDMENT)	STEEL
M	3/16" X 2-1/4" PFH ITW CONCRETE SCREW	STEEL
1	JAMB (DOOR)	WOOD
3	JAMB (TRANSOM - DIRECT SET)	WOOD
4	MULLION	LVL
7	WEATHERSTRIP	FOAM
8	SWEEP	VINYL
14	OUTSWING THRESHOLD	ALUM/COMP
15	INSWING THRESHOLD	ALUM/COMP
16	ADA THRESHOLD	ALUM
23	#10 X 1-1/2" PFH WOOD SCREW	STEEL
24	#12 x 1" PFH WOOD SCREW	STEEL
25	#8 x 1-3/4" PFH WOOD SCREW	STEEL
26	#8 x 2-1/2" PFH WOOD SCREW	STEEL
29	4.5" X 4.5" HINGE	STEEL
31	SHOOTBOLT STRIKE PLATE	STEEL
35	ASTRAGAL	WOOD
36	MULTIPOINT STRIKE PLATE	STEEL
37	MULTIPOINT ROUND BOLT STRIKE DETAIL	STEEL
38	MULLION ANGLE CLIP (USP ML24-TZ)	STEEL
40	DOOR PANEL	WOOD
41	DOOR PANEL	WOOD
50	SIDELITE PANEL	WOOD
51	SIDELITE PANEL (DIRECT SET)	WOOD
70	TRANSOM PANEL	WOOD

WOOD FRAME COMPONENTS: SIPO (UTILE) (G = 0.53)

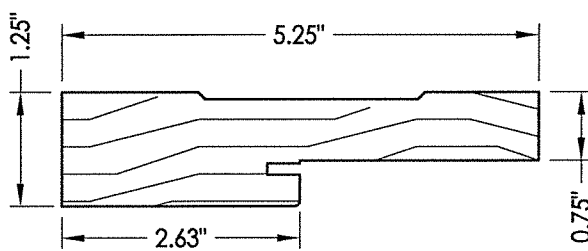

1 WOOD JAMB (DOOR)

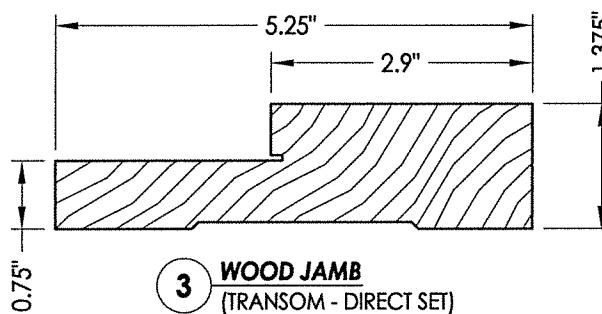

3 WOOD JAMB (TRANSOM - DIRECT SET)

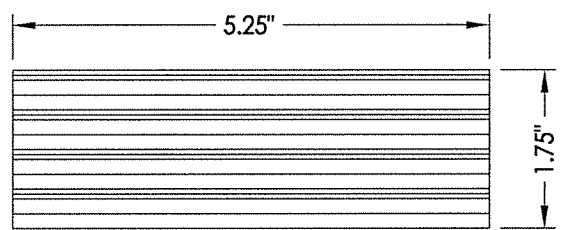

4 MULLION VERSA-LAM® 3100 Fb-2.0E

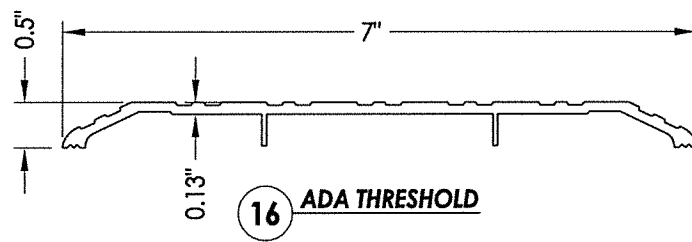

16 ADA THRESHOLD

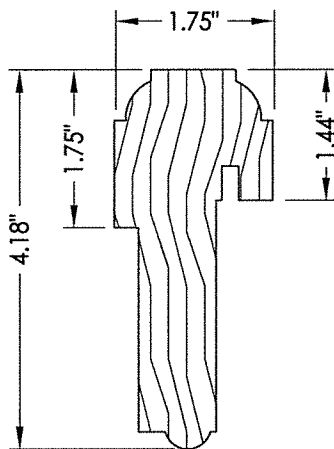

35 ASTRAGAL

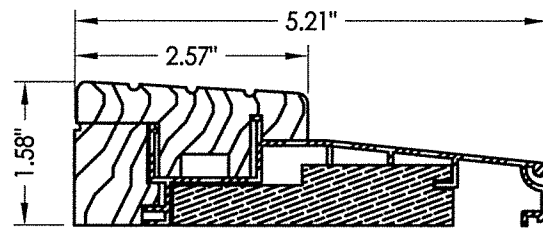

15 INSWING THRESHOLD WORLDWIDE

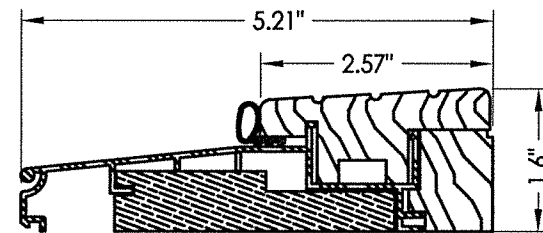

14 OUTSWING THRESHOLD WORLDWIDE

CONCRETE ANCHOR NOTES:

- Concrete anchor locations at the corners may be adjusted to maintain the min. edge distance to mortar joints.
- Concrete anchor locations noted as "MAX. ON CENTER" must be adjusted to maintain the min. edge distance to mortar joints, additional concrete anchors may be required to ensure the "MAX. ON CENTER" dimension are not exceeded.
- Concrete anchor table:

ANCHOR TYPE	ANCHOR SIZE	MIN. EMBEDMENT	MIN. CLEARANCE TO MASONRY EDGE	MIN. CLEARANCE TO ADJACENT ANCHOR
ITW TAPCON®	1/4"	1-1/4"	2"	4"
ELCO ULTRACON®	1/4"	1-1/4"	1"	4"
ITW TAPCON®	3/16"	1-1/4"	3"	1-1/2"

WOOD SCREW INSTALLATION NOTES:

- Maintain a minimum 5/8" edge distance, 1" end distance, & 1" o.c. spacing of wood screws to prevent the splitting of wood.

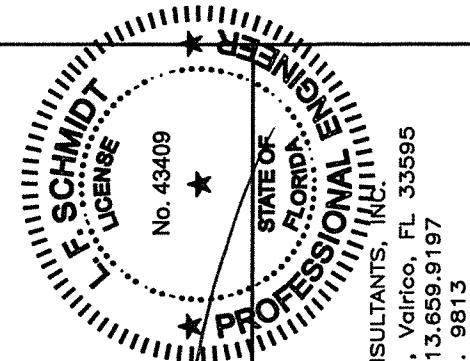

October 12, 2017
 Documents Prepared By:
 Lyndon F. Schmidt
 P.E. No. 43409

RW BUILDING CONSULTANTS, INC.
 P.O. Box 230, Vairico, FL 33595
 Phone No.: 813.659.9197
 FBPE C.A. No. 9813

PRODUCT: SOUTHEASTERN SASH & DOOR WOOD DOOR
 PART OR ASSEMBLY: BILL OF MATERIALS & COMPONENTS

NO.	DATE	DESCRIPTION	BY
1	10/12/17	UPDATE TO 6TH ED. (2017) FBC	LFS

DATE: 5/10/17
 SCALE: N.T.S.
 DWG. BY: JK
 CHK. BY: LFS
 DRAWING NO.: FL-22347.10
 SHEET 13 OF 13